

APPLICATION NOTE	AN-Lift2-0015v100EN
Rescue operation	

<b>Inverter type</b>	FRENIC-Lift (LM2A)
<b>Software version</b>	0500 (or later) for “Deliverance Operation”
<b>Required options</b>	Speed feedback option
<b>Related documentation</b>	INR-SI47-1909a-E
<b>Author</b>	Carlos Arjona
<b>Use</b>	Public, web
<b>Date</b>	11/05/2023
<b>Version</b>	1.0.0
<b>Languages</b>	English

## 1. Introduction

Some lifts include the function to automatically rescue people in case of mains blackout while lift is travelling. This function is known as rescue operation or emergency operation.

The aim of this document is to explain how to wire and how to program the inverter for a rescue operation. It will explain as well the different available modes:

- Rescue by recommended running direction
- Rescue by deliverance operation
- Rescue by brake control (gravity)

During rescue operation, an alternative power supply is going to be used. Most common power supplies used in lift market are UPS or batteries. This document does not pretend to explain how to size the alternative power supply.

## 2. Power terminals wiring

As mentioned before, there are three different types of rescue operation; recommended running direction and deliverance operation will actually drive the motor, rescue by gravity not.

In the rescue operations where we are going to drive the motor, we can supply the inverter by means of UPS only, by means of batteries only or by means of a combination of batteries and UPS. Inverter capacity will define which type I can use. Two magnetic contactors will be used to choose the power supply, MC1 for mains supply and MC2 for auxiliary power supply.

An auxiliary contact of MC2 can activate as well the digital input function *BATRY*. This function is set by default on the terminal X8. In case that the inverter is controlled by communications please refer to Chapter 8.

In case of rescue operation by brake control, only control board needs to be supplied.

On the following sub chapters, we are going to show the power terminals and X8 terminal connection depending on each case.

## 2.1. Connection diagram in case of batteries only (FRN0032LM2A-4E or below)

This section also applies for models with single phase 200V power supply (FRN0011LM2A-7E and FRN0018LM2A-7E).

Control board will be supplied by an independent power supply in order to warranty that CPU is alive during the complete operation. Control board is supplied by means of terminals +24V and -24V. Control board requires a steady supply of at least 40 W.

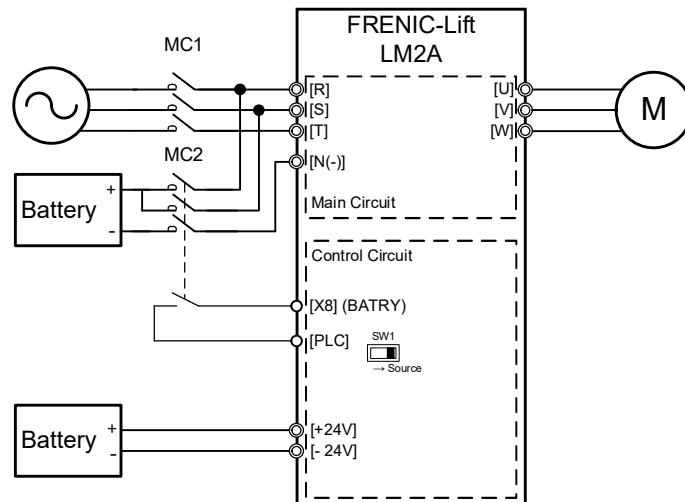

Figure 1. Battery connection for FRN0032LM2A-4E or below.

## 2.2. Connection diagram in case of batteries and UPS (FRN0039LM2A-4E and above)

In case of 0039 A and above, the control circuit requires by 1ph 200 VAC on terminals R0 and T0, therefore additionally to batteries, an UPS is required. Control board requires a steady supply of at least 40 W.

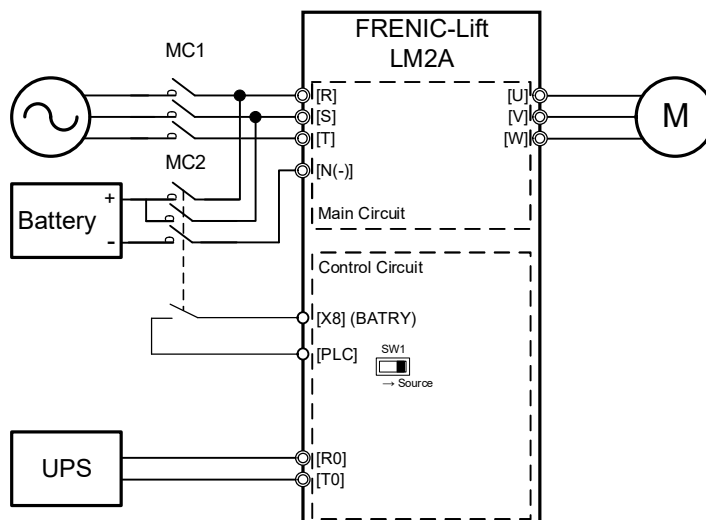

Figure 2. Battery and UPC connection for FRN0039LM2A-4E and above.

### 2.3. Connection diagram in case of UPS only

In case of using a UPS for the rescue operation, there is no restriction on inverter size. UPS supplies enough voltage on the DC link in order to keep CPU alive safely, therefore specific supply for control board is not required.

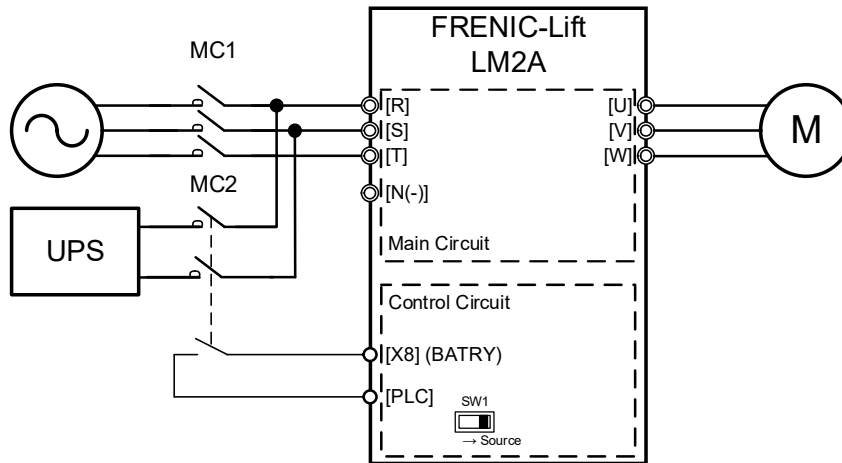

Figure 3. UPS connection.

### 2.4. Connection diagram for rescue by brake control (FRN0032LM2A-4E or below)

In case of rescue operation by brake control, we only need to supply the control board as explained before, for these capacities this will be done in terminals +24 and -24 V by means of batteries. On the other hand, a digital input needs to be activated as well but with a different function (*RBRK*). For details regarding that function, please refer to Chapter 6.

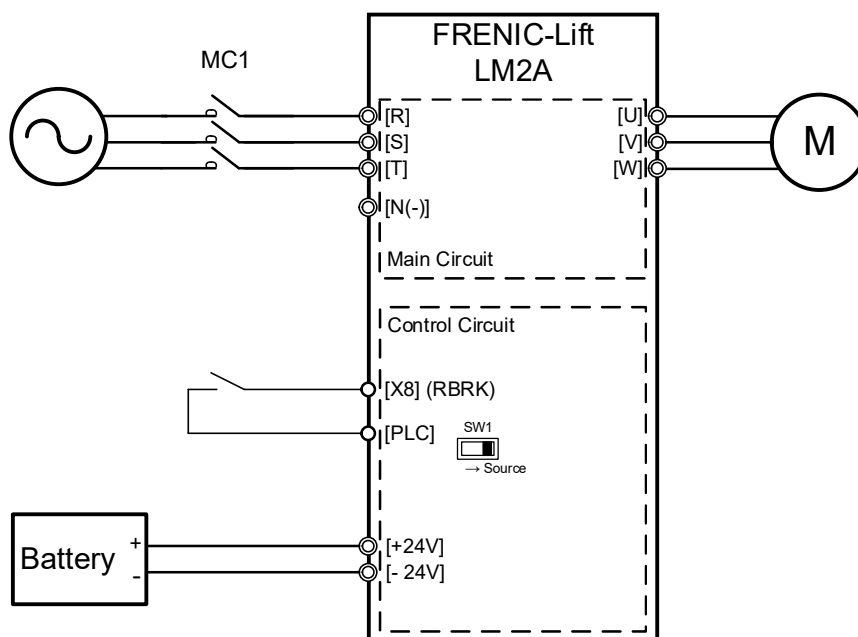

Figure 4. Rescue operation by brake control for FRN0032LM2A-4E or below.

## 2.5. Connection diagram for rescue by brake control (FRN0039LM2A-4E and above)

For these capacities, control board is supplied by terminals R0 and T0 by means of an UPS. On the other hand, a digital input needs to be activated as well but with a different function (*RBRK*). For details regarding *RBRK* function, please refer to Chapter 6.

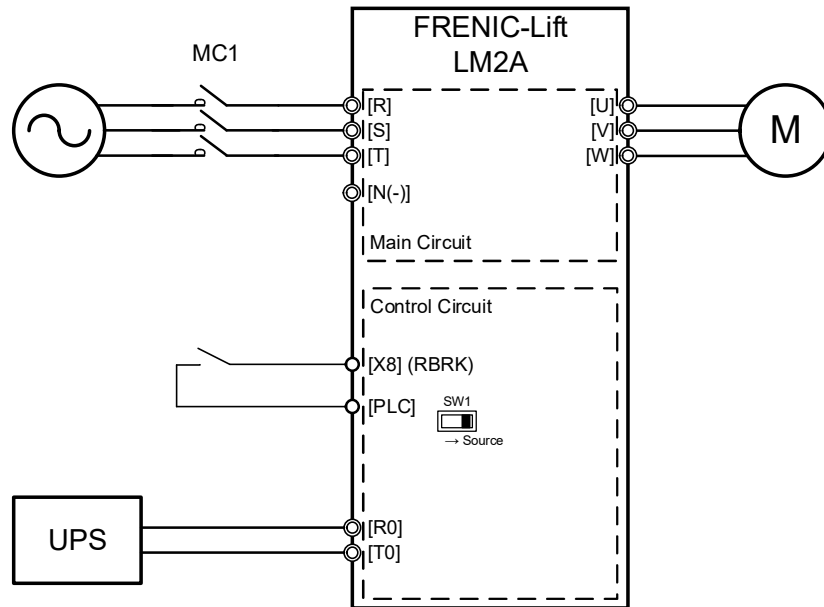

Figure 5. Rescue operation by brake control for FRN0039LM2A-4E and above.

## 3. Sequence for power supply

The sequence explained in this chapter is only important in the cases where motor is controlled during rescue operation (Chapters 2.1, 2.2 and 2.3 on this document). It means when rescue is done by recommended running direction or by deliverance operation.

Sequence for rescue operation regardless of the direction command is detailed in Figure 6. As soon as the *BATRY* signal is activated, undervoltage level alarm is reduced to level L125 in order to allow the operation when supply comes from UPS or batteries. Used speed can be the specified for the battery operation (C03, combination on L12) or any other speed.

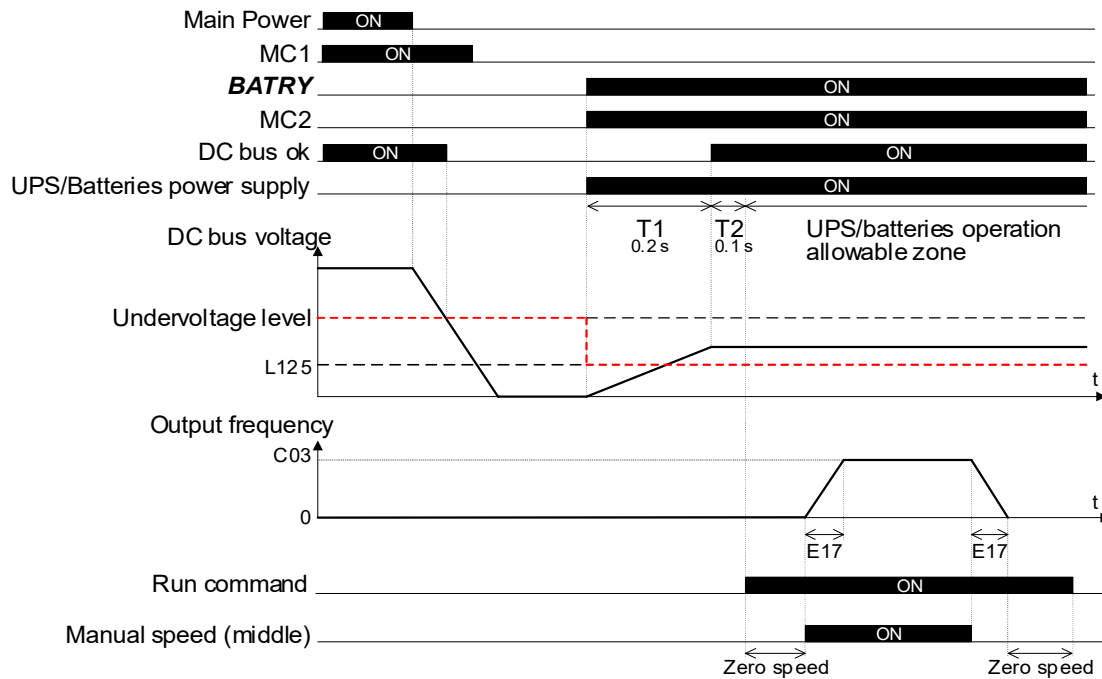

Figure 6. Operation sequence regardless of direction command.

#### 4. Recommended running direction (RRD)

This chapter explains the first rescue mode, when inverter recommends the running direction. First, we explain the setting you must do on the inverter, afterwards the operation sequence. This operation corresponds with the diagrams shown in Chapters 2.1, 2.2, 2.3 and 3.

##### 4.1. Setting

In order to set this function, it is mandatory to set all parameters as detailed at table 1 for the correct behaviour during rescue.

Table 1. RRD function setting.

Function code	Name	Factory setting	Units / Symbol	Range
E01 to E08, E98 and E99	Command assignment [X1] to [X8], [FWD] and [REV]	Depends on terminal	<b>BATRY</b>	<b>63 (1063)</b>
			<b>SS1, SS2, SS4</b>	<b>0, 1, 2</b>
			<b>FWD, REV</b>	<b>98, 99</b>
E20 to E24, E27	Command Assignment for [Y1] to [Y5], [30]	Depends on terminal	<b>RRD</b>	<b>109 (1109)</b>
E39	RRD detection level	0	%	0 to 100
C03	Battery operation speed	Depends on C21	Depends on C21	Depends on C21
L125	UPS / batteries minimum operation level	24 (200V series)	V	20 to 220
		30 (400V series)		30 to 440

- Digital inputs  
(Function code E01 to E08, E98 and E99)

To perform rescue operation by recommended running direction we must have two digital inputs to select rescue operation direction (*FWD* or *REV*). By factory default these functions are on terminals *FWD* and *REV* respectively.

We will need as well digital inputs to select desired speed (*SS1*, *SS2* and *SS4*). By factory default these functions are on terminals *X1*, *X2* and *X3* respectively.

Finally, we will need a digital input to inform that we are going to operate with low voltage (*BATRY*). By factory default this function is on terminal *X8*.

- Digital outputs  
(Function code E20 to E24, E27)

This function is not coming on factory default setting therefore, Assign *RRD* function to one of the digital outputs (parameters from E20 to E24 and E27 to value 109).

This function monitors in which direction motor was braking (generating energy) in the last movement. This function only works in closed loop control, therefore when motor has an encoder. The *RRD* function will be permanently updated in normal operation, and the value will not change from the moment *BATRY* is activated.

Therefore, when the rescue starts, if this output is *ON* means that the recommended direction is *FWD*; otherwise, if this output is *OFF*, the recommended direction is *REV*.

Table 2. *RRD* function state

<i>RRD</i>	Specification
OFF	The inverter recommends the reverse direction ( <i>REV</i> )
ON	The inverter recommends the forward direction ( <i>FWD</i> )

- *RRD* direction level  
(Function code E39)

This parameter sets the detection level of the recommended running direction for battery operation.

When inverter is controlling a motor with low efficiency (like worm gear induction motor), load variation between car and counterweight might not be detected. In this case, please set this level to detect *RRD* correctly.

Please follow the procedure described below in order to adjust E39 properly:

1. With balanced load, run the elevator in up direction and observe the torque command at constant speed.
2. With same condition, run the elevator in down direction and observe the torque command at constant speed.
3. Please set E39 to the larger torque command observed among step 1 and 2.

- Battery operation speed  
(Function code C03)

When *BATRY* is activated, and binary combination set on L12 is selected, inverter will drive the motor at speed set on C03 instead of C05. This is understood as the battery operation speed. For this speed there are no S-curves and acceleration / deceleration ramps are set on E17.

Set on C03 the speed rescue operation wanted to be performed. It is common to set this speed at 10% of motor rated speed.

It is possible to use a different binary combination. In this case, the rescue speed will be the one selected by the binary combination (from C04 to C11).

- UPS / Batteries minimum operation level  
(Function code L125)

This function code defines the Low voltage trip level when *BATRY* is activated. Set a value above minimum DC voltage level needed to perform desired rescue operation.

## 4.2. Operation sequence

Figure 7 shows an example of how the function works before and during rescue operation. As it can be observed, in normal operation the inverter monitors the drive state (D: Driving, B: Braking) when the inverter is in RUN (FWD or REV) and speed is constant. When the lift is accelerating or decelerating, drive state is not processed as it might lead to miscalculation.

In the example below, we see the first movement in FWD direction and driving (D). This movement could correspond for example to car empty driving down direction. Next movement is in REV direction and driving again (D). This could be car full going up. Under this condition there is a blackout and system stops. When system restarts with *BATRY* function activated, inverter informs by RRD function that rescue operation should be carried out in FWD direction (down: braking) because when there was a blackout lift was moving in REV and driving (D). This is why when operation mode is in battery operation, controller selects FWD direction to perform the rescue.

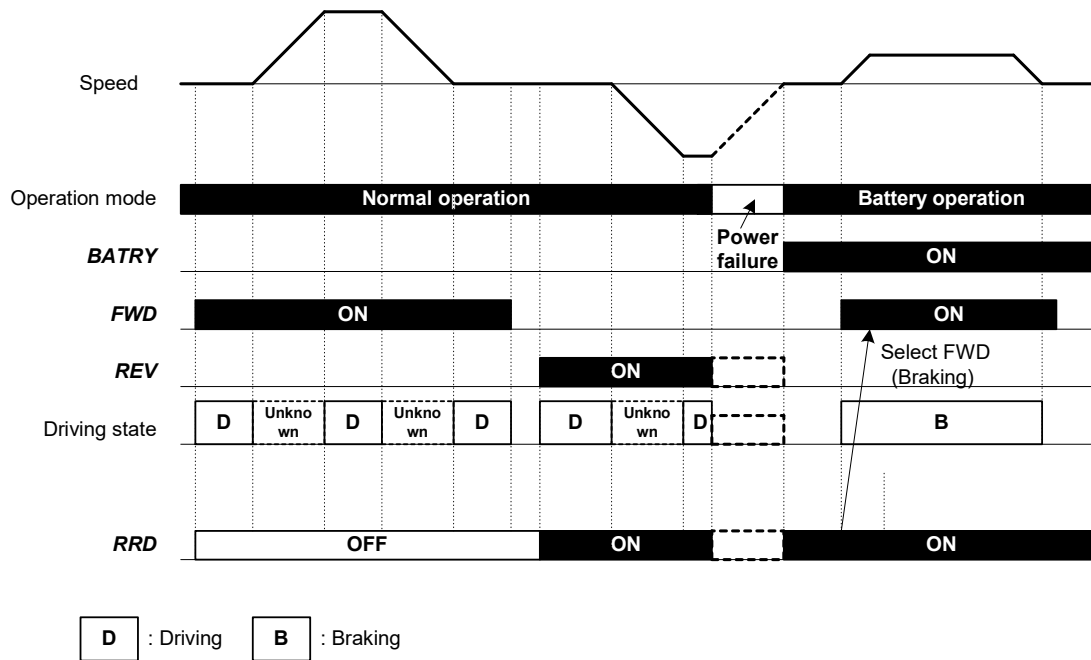

Figure 7. RRD sequence behaviour.

## 5. Deliverance operation

This chapter explains how rescue operation by deliverance operation is performed. First, we explain the setting you must do on the inverter, afterwards the operation sequence. This operation corresponds with the diagrams shown in Chapters 2.1, 2.2, 2.3 and 3.

### 5.1. Setting

Using this function, inverter calculates and executes the best direction for rescue accordingly to the requirements set at parameters L122, L123 and L124. For the correct behaviour of this function, it is mandatory to set the parameters detailed at table 3.

Table 3. Setting for Deliverance operation.

Function code	Name	Factory setting	Units / Symbol	Range
E01 to E08, E98 and E99	Command assignment [X1] to [X8], [FWD] and [REV]	Depends on terminal	<b>BATTERY</b>	<b>63 (1063)</b>
			<b>SS1, SS2, SS4</b>	<b>0, 1, 2</b>
			<b>FWD, REV</b>	<b>98, 99</b>
E20 to E24, E27	Command Assignment for [Y1] to [Y5], and [30]	Depends on terminal	<b>CEND</b>	<b>124 (1124)</b>
C03	Battery operation speed	Depends on C21	Depends on C21	Depends on C21
L122	Input power detection level	100	%	1 to 200% (of inverter rated power)
L123	Direction Calculation Setup	0000 0000	-	0000 0000 to 0000 0111
L124	Direction Calculation Delay Timer	0.30	s	0.00 to 1.00
L125	UPS / batteries minimum operation level	24 (200V series)	V	20 to 220
		30 (400V series)		30 to 440

- Digital inputs  
(Function code E01 to E08, E98 and E99)

To perform rescue operation by deliverance operation we must activate a direction (FWD or REV). Independently of the direction selected, operation will start always in FWD direction.

We will need as well digital inputs to select desired speed (SS1, SS2 and SS4). By factory default these functions are on terminals X1, X2 and X3 respectively.

Finally, we will need a digital input to inform that we are going to operate with low voltage (BATRY). By factory default this function is on terminal X8.

- Digital outputs  
(Function code E20 to E24, E27)

CEND function programmed in any of the digital outputs can be used to detect when deliverance operation direction is decided. For additional information check the Chapter 5.2.

- Battery operation speed  
(Function code C03)

When BATRY is activated, and binary combination set on L12 is selected, inverter will drive the motor at speed set on C03 instead of C05. This is understood as the battery operation speed. For this speed there are no s-curves and acceleration/deceleration ramps are set on E17.

Set on C03 the speed rescue operation wants to be performed. It is common to set this speed at 10% of motor rated speed.

It is possible to use a different binary combination. In this case, the rescue speed will be the one selected by the binary combination (from C04 to C11).

- Deliverance operation - Input power detection level  
(Function code L122)

This parameter is used to define input power detection level. In other words, inverter will allow rescue operation as long as input power remains equal or below L122 level under certain conditions. L122 level is set in percentage and it is referred to inverter rated power.

- Deliverance operation - Direction calculation setup  
(Function code L123)

L123 is a byte parameter. Depending on setting of bit 0, 1 and 2, behaviour of deliverance operation is decided. Bit meaning is explained in table 4.

Table 4. Meaning of L123 bits.

bit	Bit setting description
<b>bit0</b> Activation	0: Function disabled. If <b>BATRY</b> input function is enabled, inverter will behave as current FRENIC-Lift during rescue mode. In other words, motor will turn <b>FWD</b> or <b>REV</b> depending on input terminal activation.
	1: Function enabled. If <b>BATRY</b> input is activated, motor will turn in different directions depending on the setting of <b>bit1</b> , <b>bit2</b> , <b>L122</b> and <b>L124</b> .
<b>bit1</b> Input power level reached criteria	0: Cancel deliverance operation If during calculation, it is detected that in both directions (FWD and REV), level L122 is reached, deliverance operation is stopped. In other words, inverter will not try to run the motor to any direction.
	1: Take the direction with the highest output frequency. In this case, the selected direction will be the one with the highest output frequency when the Input power detection level is reached.
<b>bit2</b> Directions test criteria	0: Move in <b>FWD</b> direction Regardless of input terminal activation (RUN command), deliverance operation will turn the motor always in <b>FWD</b> direction. If level L122 is not reached, deliverance operation will be finished when RUN command is removed.
	1: Move in <b>FWD</b> and <b>REV</b> direction Regardless of input terminal activation (RUN command), deliverance operation will turn the motor always in <b>FWD</b> direction. After few seconds motor will be stopped and <b>REV</b> direction will be tested. Deliverance operation will be finished in the direction of the RUN command with the lowest input power consumption.

- Deliverance operation - Direction calculation delay timer (Function code L124)

Inverter will wait the time specified at L124 to start the deliverance operation calculation.

## 5.2. Operation sequence

Using the deliverance operation, the result of the calculation and rescue behaviour will depend of the installation conditions and inverter setting. Below table shows the different possible results and the related figure to check the sequence:

Table 5. Deliverance operation behaviour depending on L123 setting

Case	L123	FWD power input level > L122?	REV power input level > L122?	Comparison Result	Calculation Result	Related Picture
A1	001	No	-	-	FWD	Fig. 8
B1	001	Yes	No	-	REV	Fig. 9
C1	001	Yes	Yes	-	STOP	Fig. 10
A2	011	No	-	-	FWD	Fig. 8
B2	011	Yes	No	-	REV	Fig. 9
D1	011	Yes	Yes	$f_{out1} < f_{out2}$	REV	Fig. 11
E1	011	Yes	Yes	$f_{out1} > f_{out2}$	FWD	Fig. 12
F1	101	No	No	$P_{in1} < P_{in2}$	FWD	Fig. 13
G1	101	No	No	$P_{in1} > P_{in2}$	REV	Fig. 14
B3	101	Yes	No	-	REV	Fig. 9
H1	101	No	Yes	-	FWD	Fig. 15
C2	101	Yes	Yes	-	STOP	Fig. 10
F2	111	No	No	$P_{in1} < P_{in2}$	FWD	Fig. 13
G2	111	No	No	$P_{in1} > P_{in2}$	REV	Fig. 14
B4	111	Yes	No	-	REV	Fig. 9
H2	111	No	Yes	-	FWD	Fig. 15
D2	111	Yes	Yes	$f_{out1} < f_{out2}$	REV	Fig. 11
E2	111	Yes	Yes	$f_{out1} > f_{out2}$	FWD	Fig. 12

- Cases A1 and A2:

The operation in cases A1 or A2 is shown in the picture below (Figure 8):

- After activating the “Low Voltage Cancellation” signal (**BATRY**), if a RUN command is given to the inverter (**FWD** or **REV** signals will have the same behavior), the deliverance sequence starts. The first direction to be tested will always be **FWD**.
- After waiting for the brake release (in **L82**), the time set in **L124** will be waited until the start of the Best Direction Calculation Sequence. (\*)
- During the direction calculation sequence, the inverter input power will be monitored while trying to move the load in one direction.
- The direction calculation sequence will last until the motor reaches the constant speed level.  
**Note:** If the effective acceleration and deceleration times are set to zero (for example, when the speed profile is given to the inverter by means of an analog input), the inverter will consider that the frequency is constant if the acceleration ramp is equivalent to 60 s or longer.
- If, like in the picture below, the input power value is not bigger than **L122** (and **L123** bit2 is 0) it is understood that the actual direction is the right one for minimum power consumption. Therefore, the deliverance sequence will continue until the run command is removed.
- Once the decision is made, the **CEND** output is activated. Together with the **FRUN** and **RRUN** output signals, the user can know if the decision has been made and which direction is the chosen one.

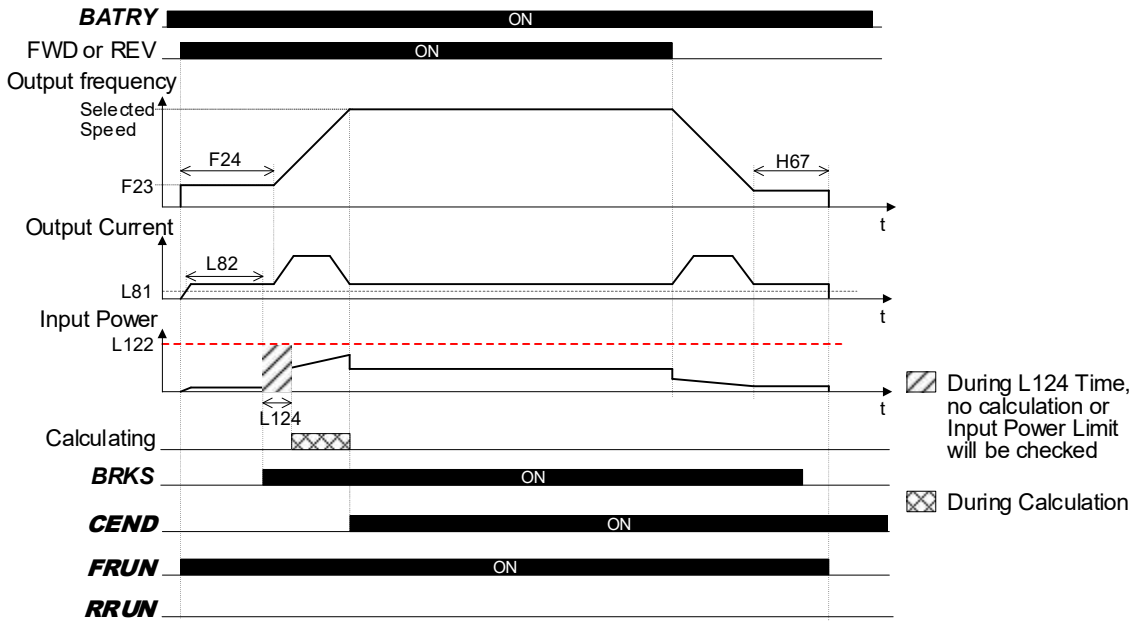

Figure 8: CASES A1 or A2 behaviour

(\*) **Note:** The brake signal must be activated and configured properly in order to use the “Deliverance Operation” function. L81 level is used only in case of L80=2.

- Cases B1, B2, B3 and B4:

On the other hand, if the input power value arises over the value in **L122**, the inverter will stop the **RFWD** operation, and will start the calculation procedure, but this time in Reverse Direction. In this new procedure, if the maximum input power value is lower than the level in **L122**, the deliverance operation will continue in reverse direction until the RUN Command is removed.

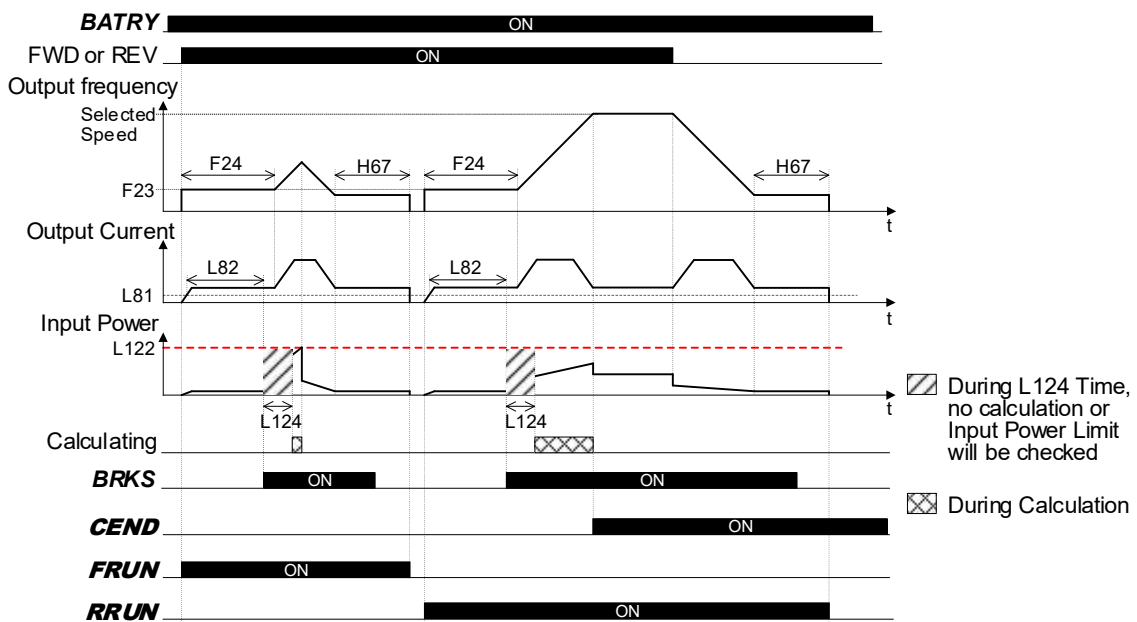

Figure 9: Cases B1, B2, B3 or B4 behaviour

- Cases C1 and C2:

If the input power is bigger than **L122** in **FWD** and **REV** directions and bit1 of **L123** is set to 0, the deliverance operation will finish as soon as the direction calculation procedure is over (Figure 10). Once the deliverance operation is over, will be necessary to remove the RUN command and switch it on again, in order to try to perform the Deliverance operation again.

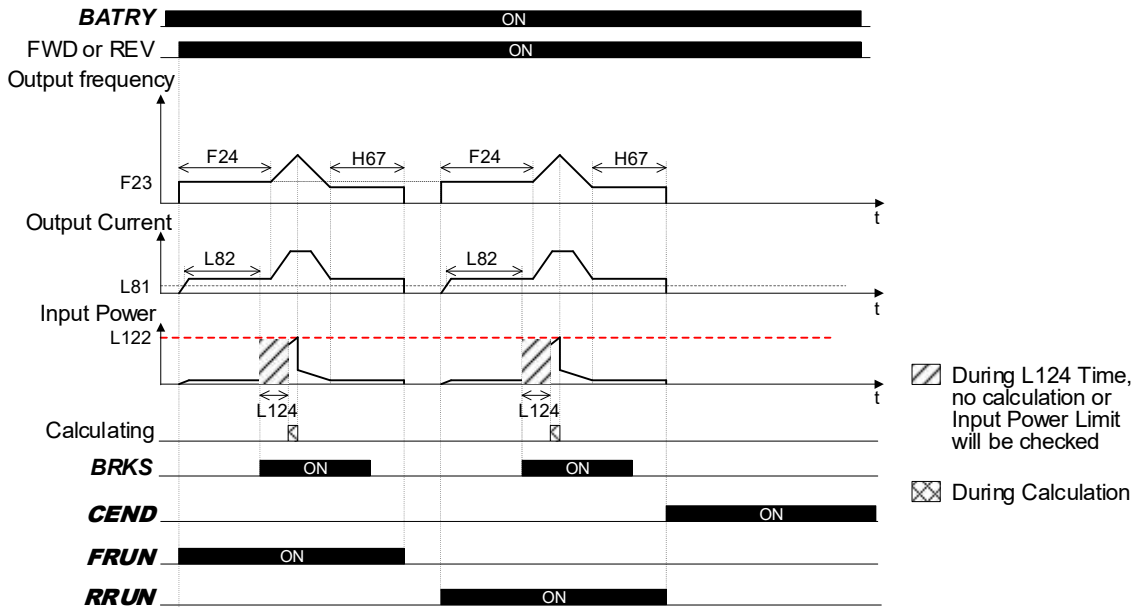

Figure 10: Cases C1 or C2 behaviour

- Cases D1 and D2:

If the **L123** bit1 is set to 1, the inverter is allowed to try to continue the deliverance operation even if the input power limit has been bigger than the value in **L122**. To do so, when the inverter stops due to the input power level, it saves the output frequency value, and considers that the best direction is the one with the higher frequency. In case that this direction is reverse, as shown below, the inverter will continue running until the RUN Command is removed.

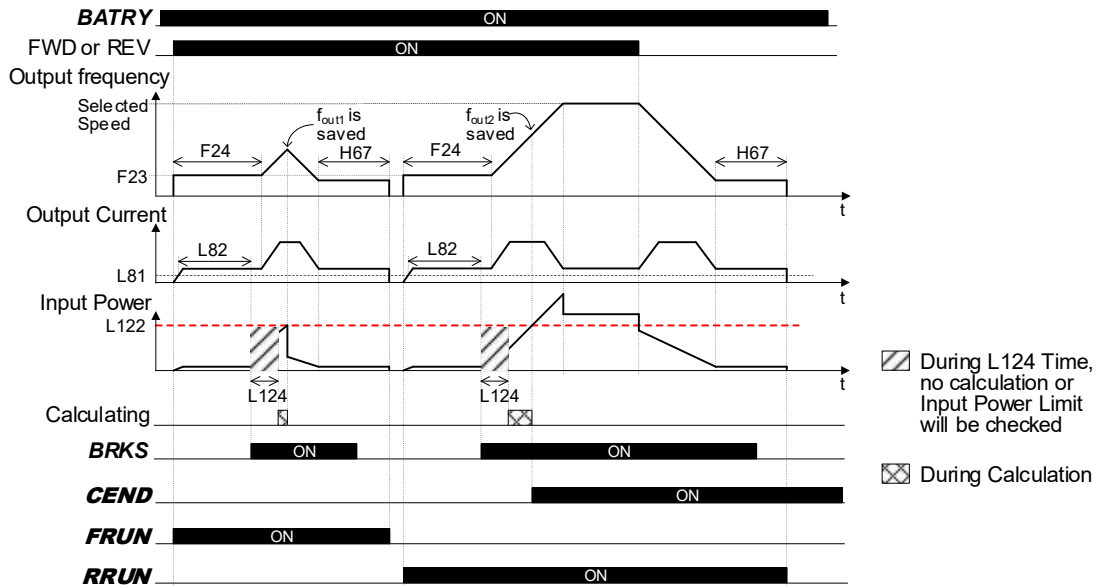

Figure 11: Cases D1 or D2 behaviour

- Cases E1 and E2

When bit1 of **L123** is set to 1, if the frequency saved in reverse is lower than the frequency in forward, the inverter will automatically choose the **FWD** direction as the best one. Therefore, the inverter will stop and will decide to perform the Deliverance operation in Forward Direction.

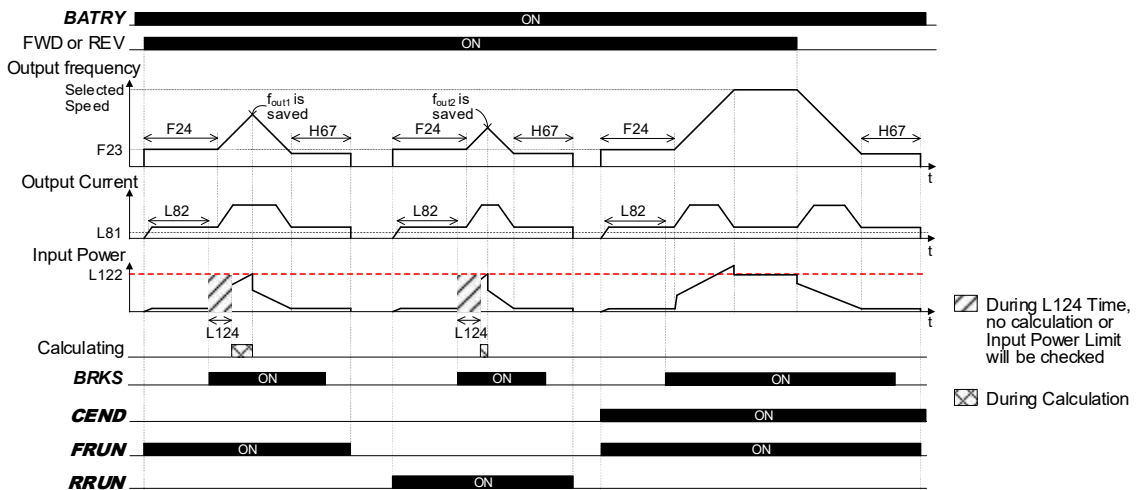

Figure 12: CASES E1 or E2 behaviour

- Cases F1 and F2

Concerning the bit2 of **L123**, its value determines if the inverter must test both directions (bit2 set to 1) or can skip the test in reverse direction if the input power value in forward direction is lower than **L122**. The behavior depicted in the pictures above is obtained with bit2 set to 0 but, in the Figures 13 and 14, it is possible to find examples of bit2 set to 1.

If the input power value is lower than **L122**, the inverter will continue testing up to reaching the command frequency, and then it will stop to test the other direction. Under these conditions, the inverter will save the maximum input power of each direction, and

will decide the best direction based on this level. In figure 13, Forward direction is decided.

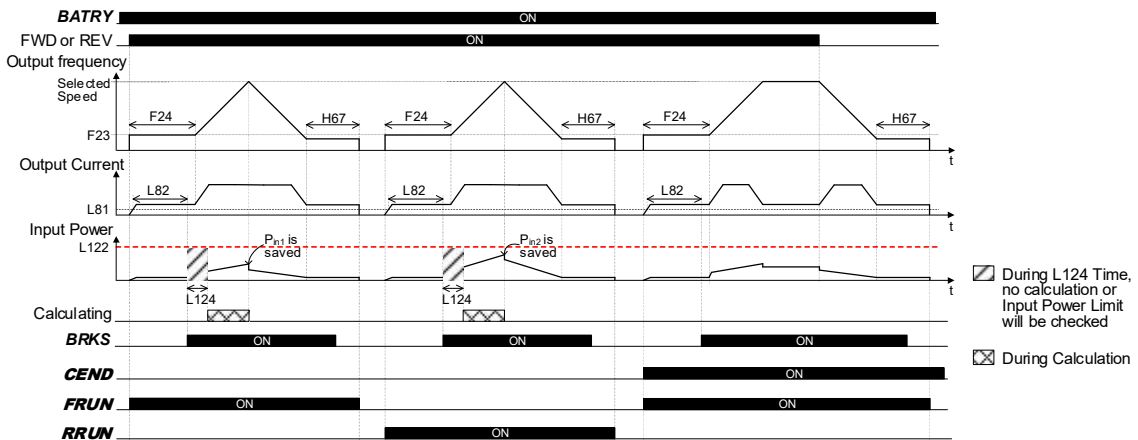

Figure 13: Cases F1 or F2 behaviour

- Cases G1 and G2:

Another possible case when the bit2 of **L123** is set to 1 is depicted in Figure 14. Reverse direction is decided due to the lower value of  $P_{in2}$  respect to  $P_{in1}$ . Therefore, the motor keeps going in **REV** direction.

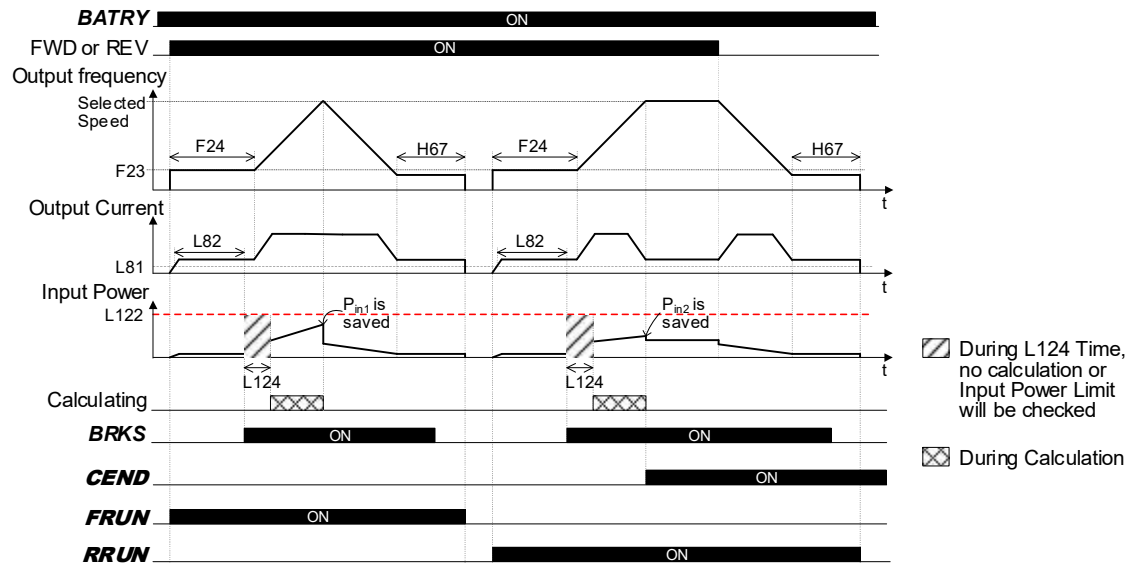

Figure 14: Cases G1 or G2 behaviour

- Cases H1 and H2:

The last possibility, when bit2 of **L123** is set to 1, is shown in the picture below (Figure 15). In this case, **FWD** direction is decided due to the fact that, in **REV** direction, the input power reached the value in L122. Therefore, no calculation is needed in this time.

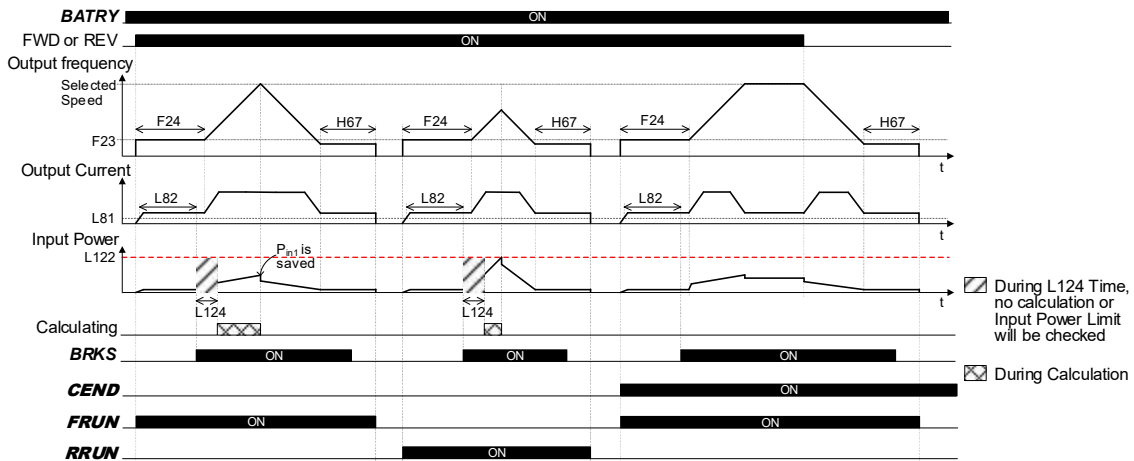

Figure 15: Cases H1 or H2 behaviour

## 6. Rescue by gravity

This chapter explains how rescue operation by deliverance operation is performed. First, we explain the setting you must do on the inverter, afterwards the operation sequence. This operation corresponds with the diagrams shown in Chapters 2.4 or 2.5

### 6.1. Setting

With this operation it is pretended to move the cabin after the blackout controlling the motor brake and monitoring the speed. For that reason, the encoder is mandatory in this operation. Movement would be done by gravity (load unbalance between cabin and counterweight).

Table 6. Setting for rescue by gravity.

Function code	Name	Factory setting	Unit / Symbol	Range
E01 to E08, E98 and E99	Command assignment [X1] to [X8], [FWD] and [REV]	Depends on terminal	<b>RBRK</b>	<b>114</b>
L108	Detection speed	10.0	mm/s	From 0.0 to 500.0
L117	Rescue operation by brake control (Speed limit)	100.0	mm/s	From 0.0 to 500.0
L118	Rescue operation by brake control (Apply time)	0.20	s	From 0.10 to 2.00
L119	Rescue operation by brake control (Speed detection delay time)	0.50	s	From 0.00 to 3.00
K23	Travel direction display	0	-	0 and 1

- Digital inputs (Function code E01 to E08, E98 and E99)

To perform rescue operation by brake control we must activate a digital input programed with the function **RBRK**.

When this input function is set to ON *BRKS* output function behavior changes. In this case, *BRKS* output function depends on L117 and L118 setting. For additional details refer to chapter 6.2.

- Digital outputs  
(Function code E20 to E24, E27)

To perform rescue operation by brake control we must have a digital output programmed with the function *BRKS*. By factory default this function is programmed on the terminal [Y5A/C]

- Speed detection threshold  
(Parameter L108)

This parameter is used as a lift speed threshold to determine if motor is moving or not.

Any speed detected over L108 level will be understood as a real lift car movement. Any speed detected below L108 level will be understood as a non-real lift car movement.

- Rescue operation by brake control. Speed limit  
(Parameter L117)

In this parameter the maximum speed (in mm/s) allowed during rescue operation by brakes control is set.

- Rescue operation by brake control. Closing time  
(Parameter L118)

When brake is closed and *RBRK* input function keeps activate, speed of the motor decelerates until 0 rpm. As soon as speed of the motor is below L108 level, timer L118 starts to count. After timer L118 is elapsed *BRKS* output signal will be activated again (brake will open).

Timer L118 must be set with a value below setting on L119, otherwise inverter will trip *rbA* alarm.

- Rescue operation by brake control. Speed error delay time  
(Parameter L119)

When brake is opened, as the motor will turn, some speed coming from the motor is expected. If no speed is detected, can be because motor is not turning (balanced condition or locked condition) or encoder is broken.

Parameter L119 specify the time that inverter will wait before tripping “no movement during rescue operation by brake control” alarm. This alarm is *rbA* (Rescue by Brake Alarm). Timer L119 starts to count when speed goes below L108 level.

Timer L118 must be set with a value below setting on L119, otherwise inverter will trip *rbA* alarm.

For additional information, refer to explanation about L108 parameter.

- Status icon meaning (Parameter K23)

On this parameter a cross-reference between FWD and REV and UP and DOWN direction of the lift can be defined. Meaning of K23 setting is explained in table 7. Indication on the keypad will be done by means of arrows.

Table 7. Parameter K23 setting.

K23 setting	Description	Explanation
0	Normal	RUN command in FWD means Lift moving UP (↑) RUN command in REV means Lift moving DOWN (↓)
1	Inverse	RUN command in FWD means Lift moving DOWN (↓) RUN command in REV means Lift moving UP (↑)

## 6.2. Operation sequence

While function *RBRK* is activated, the output function *BRKS* changes its behaviour and it is not dependant of RUN command. Activating this function, mechanical brake will be opened and inverter will monitor the speed detected by the encoder, closing automatically the brake if the level L117 is reached. Inverter will wait the time L118 to open again the brake.

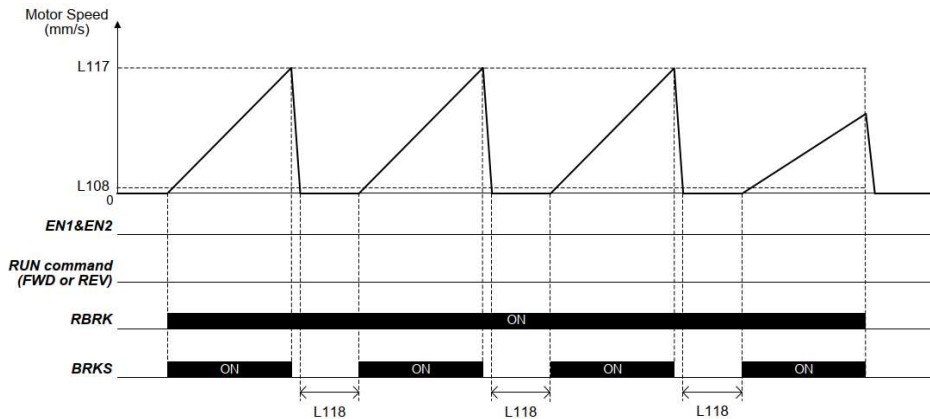

Figure 16: Sequence when L117 speed level is reached

If the level set at L117 is never reached, inverter will keep the brake opened until the function *RBRK* is switched OFF.

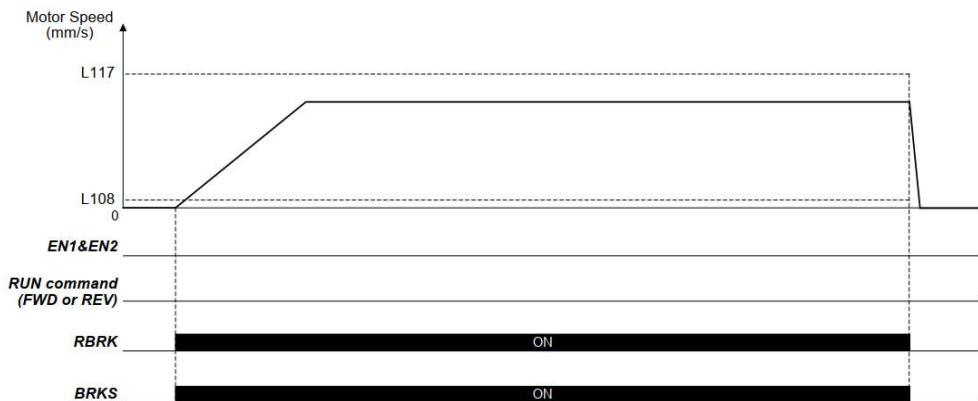

Figure 17: Sequence when L117 speed level is not reached

Inverter will wait the time L119 to reach the minimum speed level set at parameter L108. If that level is not reached, inverter will trip with *rbA* alarm and close the brake. This timer is counting every time that motor will be below level L108. This situation can appear in high friction systems or with large gear ratio, where we do not recommend the rescue with this function because the cabin may be blocked to move by gravity.

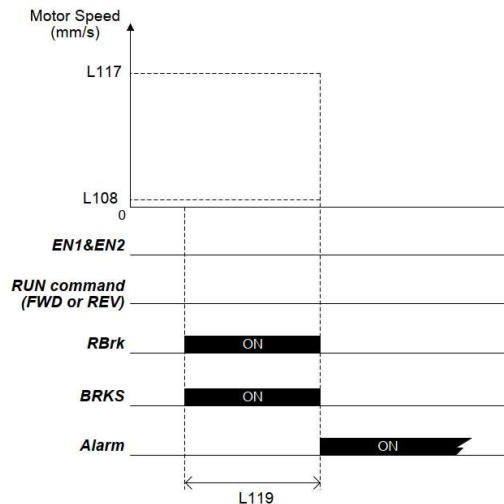

Figure 18: Inverter locked by *rbA*

## 7. Communications

This chapter will try to summarize most important things to keep in mind when inverter is controlled by communication. Most common protocols used in lift industry are DCP, CANopen CiA 402 and CiA 417.

When controller sends commands to the inverter by communications we normally set H30 to a value different than zero. In this case, some digital input functions cannot be activated by a hardware digital input. In other words, the function is activated by sending a specific frame. *BATRY* and *RBRK* are one of these functions.

### 7.1. DCP protocol

In case of DCP protocol, *BATRY* function is activated when lift controller sends the message 'I' '6'. With this message lift controller can define "Power Supply" available, where 'N' means normal and 'U' means emergency supply (equivalent to *BATRY*=ON). Please contact lift controller manufacturer to know if this function is supported or not.

Recommended running direction is supported as well. In this case the information is shown on Command byte B4.

Deliverance operation might not be supported as the lift may move in a different direction than the one requested by lift controller. Please check with lift controller manufacturer.

Rescue by brake control is not defined on DCP specifications, therefore this function cannot be activated by lift controller.

In case you want to use rescue by brake control, or lift controller does not support rescue operation, please check Chapter 7.4.

## 7.2. CiA 402

CiA 402 is an industrial protocol to define the communication protocol between controller and inverters. There are no specific lift functions defined. On the other hand, any function can be activated by sending the proper PDO or SDO message. This means that by sending or receiving PDOs or SDOs controller and inverter can simulate virtually the hardware signals *BATRY*, *RBRK*, *CEND*, etc.

In case lift controller cannot be easily adapted, please check Chapter 7.4.

## 7.3. CiA 417

CiA 417 defines a specific lift protocol. It includes some objects for rescue operation, but currently FRENIC-Lift LM2A does not support them. Additionally, functions like Deliverance operation or Rescue by brake control are not defined. Is for this that we recommend read Chapter 7.4 in this case.

Please check with lift control manufacturer if the controller accepts movements in a direction different than the selected one. Some lift controllers will trip an alarm and stop when this is detected.

## 7.4. Customizable logic

This section describes the required setting in order to generate the customizable logic to activate the *BATRY* or *RBRK* by hardware digital input when lift controller does not support these functions.

The aim of the logic is to read the physical status of one of the digital input terminals in order to activate the function through the logic. This is needed because those functions cannot be activated under communications as detailed before.

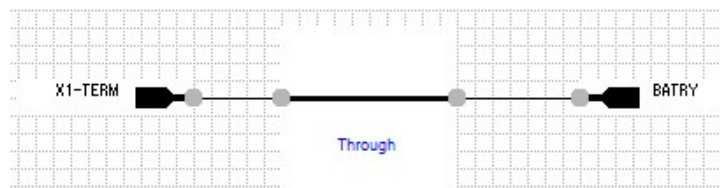

Figure 19. Block diagram for customizable logic

Below table shows the parameters to set and the required value to have the same performance as in the block diagram in Figure 19.

Table 8. Common setting.

Param.	Name	Value	Comments
U00	Mode selection	1	With U00=0 logic would be disabled
U01	Step 1: Block selection	10	
U02	Step 1: Input 1	4101	Value 4101 is for terminal X1; 4102 would be for X2, 4103 for X3, etc.
U71	Output signal 1: Output selection	1	
U81	Output signal 1: Function selection	63	<i>BATRY</i> function
		114	<i>RBRK</i> function



Terminal X1 has been selected for this setting, but it can be changed to any other terminal desired by the user. For that purpose, last digit at U02 will be changed to desired terminal, being 4101 for X1 and 4108 for X8.

## 8. Conclusion

This document describes accurately how to wire, set and how to operate the inverter in case that rescue operation is performed using the inverter.

It explains as well how to do it in case inverter is controlled by communication protocol. If this function is not supported by lift controller it explain alternatives as well.

## 9. Document history

Version	Changes applied	Date	Written	Checked	Approved
1.0.0	First version	11/05/2023	C. Arjona	J. Alonso	J. Català



# Sky Elevator®

Elevator Systems & Spare Parts



DIN EN ISO  
9001:2015



## GLOBAL BRAND



**YOU'RE SAFE WITH US**

**ALWAYS CHOOSE THE RISING QUALITY**