

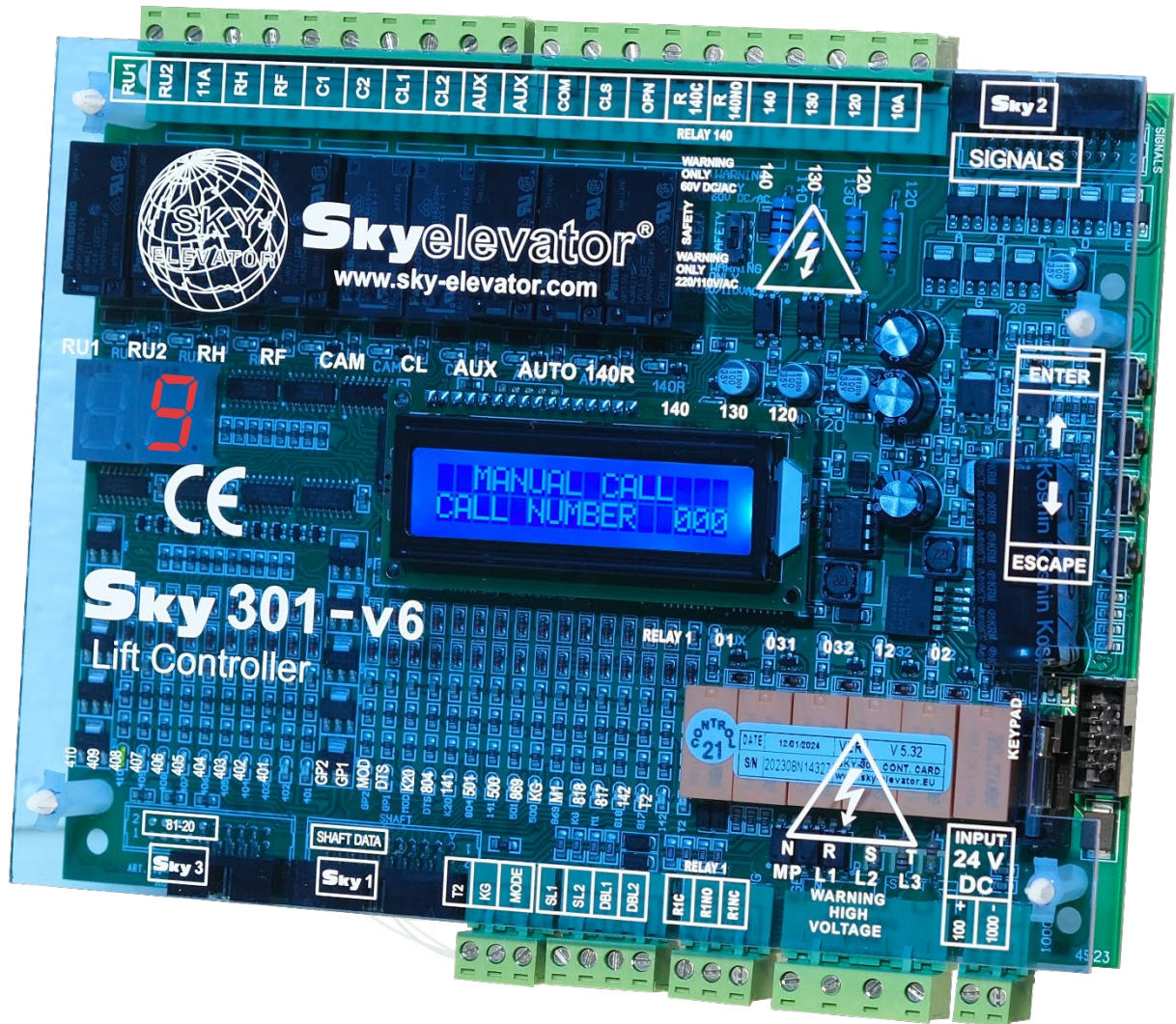

Sky
Elevator
www.sky-elevator.com



Sky 301-V6

MAIN CONTROL BOARD

USER MANUAL

V - 6.01

INDEX

SECTION 1- WARNINGS.....	2
SECTION 2- ELECTRICAL SPECIFICATIONS.....	3
SECTION 3- TECHNICAL SPECIFICATIONS.....	4
SECTION 4- EXPLANATION OF TERMINALS.....	5
SECTION 5- CHANGE PARAMETER SETTING.....	6
5.1 PARAMETER LIST.....	7
SECTION 6- AUXILIARY INPUT AND OUTPUT SETTINGS.....	10
SECTION 7- USAGE TIPS.....	11
7.1 USAGE TIPS IN CONTROL PANEL.....	13
7.2 RISK ANALYZE.....	14
SECTION 8-DIAGRAMS.....	15

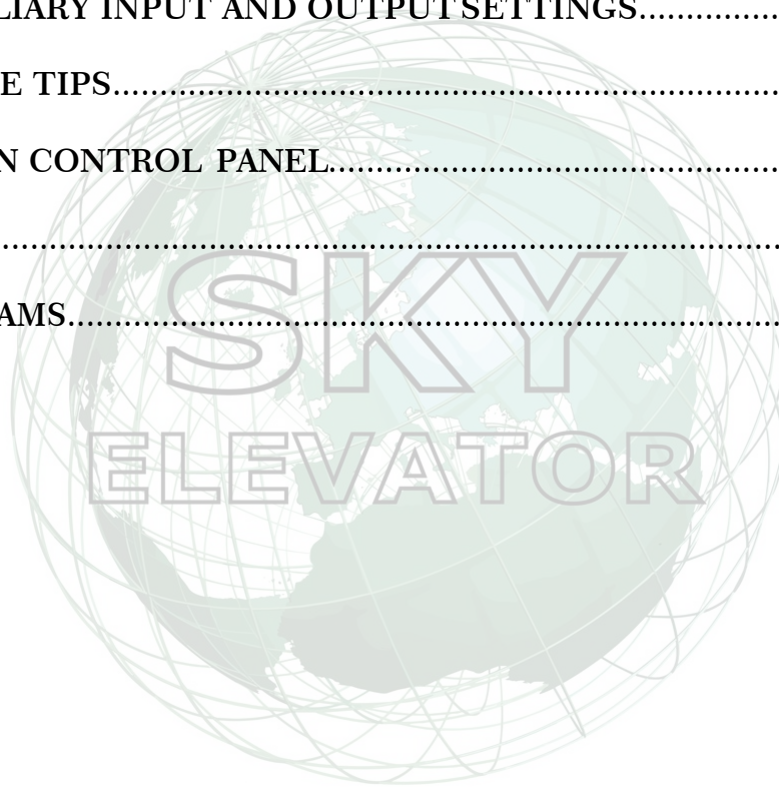

WARNINGS

CAUTION!

WHEN THE LFIT OPERATES NORMALLY, 817 AND 818 BISTABIL SWITCHES MUST NOT BE SHORTED WITH THE '100' CONNECTOR.

CAUTION!

THE SECURITY PARAMETERS (120 STOP - 130 DOOR – 140 LOCK) MUST NOT BE SHORTENED.

CAUTION!

BE SURE THAT ALL SECURITY CONTACTS OPERATE PROPERLY BEFORE PERFORM NORMAL OPERATION MODE.



CONTROL AND CLEANING

- ☞ Does not require periodic control.
- ☞ In case of a problem sent the card to the producer firm for control and fix.
- ☞ Do not connect to the liquid materials
- ☞ If needed, clean with pressured air.

ELECTRICAL SPECIFICATIONS

THIS DOCUMENT IS A SAMPLE FOR APPLICATION. ALL INFORMATIONS CONTAINED IN THIS DOCUMENT ARE SUBJECT TO CHANGE BY SKY ELEVATOR WITHOUT NOTICE. SKY ELEVATOR ASSUMES NO RESPONSIBILITY FOR ANY DAMAGE, LIABILITY OR OTHER LOSS ARISING FROM THESE INACCURACIES OR ERRORS.

OPERATION TEMPERATURE	0°C -- 60 °C
PROTECTION CLASS	IP20
MOISTURE	<%95
PHASE CONTROL	220-380V , 50/60 Hz, N
CONTROL SUPPLY VOLTAGE	10-35 ± VDC
POWER CONSUMPTION	MAX. 300 mA 8W, 10-35V DC
SECURITY CIRCUIT VOLTAGE	MAX. 60-220V AC/DC
CONTROL SIGNAL INPUT	24 -35 ± VDC
CONTROL SIGNAL INPUT WITH SHORT CIRCUIT PROTECTION	24 -35 ± VDC
MANUFACTURER	SKY ELEVATOR
	www.skyelevator.de - E-mail: sky@skyelevator.de www.sky-elevator.it - E-mail: sky@sky-elevator.it www.sky-elevator.bg - E-mail: sky@sky-elevator.bg www.sky-elevator.com - E-mail: sky@sky-elevator.com

TECHNICAL SPECIFICATIONS

- Support serial communication with no have noise and do not need the filter
- Adjustable stop numbers upper to 10 stops and memory in power off mode.
- Support Simple , down and up and full collective.
- Safety circuit can running with 40 -60 VDC/VAC warning should you set the dip switch at 60V mode in card near of safety cercuit and you should set the dip switch to 220V mode if you need working between 110 – 220 VAC/DC.
- Simplex , Group Connection,Serial Connection.
- Phase control system with fix the wrong phase automatically.
- cancel unwanted car orders (Please read in parameter table)
- Support a floor releveling status
- Support a UPS system and full control on power off mode
- Parameters can easily adjust with program buttons and LCD screen
- Overload , Full load function
- Heading towards to first predetermined floor in fire case
- Adjustable parking station and travelling time
- Full short circuit protected log (call) inputs (overheating, overcurrent, overvoltage protected)
- To all log (call) outputs 1A lamp can be directly connected
- Adjustable display output according to the intended code for each stop
- When the doors open for a long time, giving 'out of service' signal to outside buttons
- Choosing open/close waiting position of all or each floor for full automatic doors (According to EN 81-1/2 standard, 'closed waiting' must be chosen.)
- Adjustable 'waiting on the floor', 'lock waiting', 'busy time'; 'automatic door on/off' positions, 'max. high speed', 'max. low speed' times
- Automatic door card is placed on the main board; no need to use another board
- Operating in revision mode chosen by program buttons
- Adjustable time-delay relay for speed controlled lift
- Programmable auxiliary relay
- Programmable auxiliary input
- Programmable position reset
- When one of the log (call) buttons hang up, the car waits for 1 min. on this floor, then cancels this floor and continue its normal operation until the short circuit will be eliminated. Meanwhile a warning will be displayed on the LCD screen.
- Overheating, overcurrent, overvoltage protected display and log (call) outputs

EXPLANATION OF TERMINALS

R, S, T	_____	System Main Phases (Phase Control Built-In Card)
MP (N)	_____	Neutral
U, V, W	_____	Fast Motor Outputs
U1, V1, W1	_____	Slow Motor Outputs
10A	_____	Security Circuit Neutral
11A	_____	Security Circuit 140 Turning (Contactor Coil Voltage)
110	_____	Security Circuit Supply
120	_____	Security Circuit Stop Turns
130	_____	Security Circuit Door Turns
140	_____	Security Circuit Lock Turns
1F	_____	Phase (direct connected to the one of the system main phases)
1	_____	Car Socket Voltage (220V AC)
2	_____	Car Lamp (220V AC)
810 & 2001	_____	Retring Cam
840 & 2000	_____	Brake
401 – 410	_____	Car Call Button Inputs And Lamps (common 100)
142	_____	Level Stopper Magnet MKD (common 100)
817	_____	Lower-Level Stopper Magnet (common 100)
818	_____	Top-Level Stopper Magnet (common 100)
141	_____	Monostable Counter MKU Or AUX INP.2
804	_____	Overload Contact (Common 100)
KK	_____	Contactor Feedback (Common 100)
869	_____	Revision Switch Input (Common 100)
500	_____	Revision Down Input (Common 100)
501	_____	Revision Up Input (Common 100)
M1	_____	Magnet Switch for Floor Selection (Common 100)
K20	_____	Automatic Door Open Button (Common 100)
DTS	_____	Automatic Door Close Button (Common 100)
12	_____	Busy Indicator (Common Scm Connector)
31	_____	Down Indicator (Common Scm Connector)
32	_____	Up Indicator (Common Scm Connector)
a.b.c.d.e.f.g.2g	_____	Digital Display Outputs 24V DC (Common 100)
GP1	_____	Spare Input Terminal AUX INP.1
GP2	_____	Spare Input Terminal AUX INP.2
24	_____	Digital Common
100	_____	(+) 24V DC
1000	_____	(-) 24V DC
190	_____	Simple Control Common
K3 (Close)	_____	Automated Door Close Signal (With Common K15)
K5 (Open)	_____	Automated Door Open Signal (With Common K15)
K15 (Com)	_____	Common Input For K3 - K5
AU	_____	Auxiliary Relay Contact
AU	_____	Auxiliary Relay Contact

PARAMETER SETTINGS

1. Press the *'enter'* button to enter the parameter settings menu,
2. Press *'up'* or *'down'* buttons in order to find the desired setting,
3. Press *'enter'* button to change the value of the desired parameter, the chosen parameter is going to be blink, set the parameter to desired value by using *'up'* and *'down'* buttons (if you don't want to store the value in memory press *'escape'* button),
4. After setting the parameter value, press *'enter'* button to memorize it, then it passes the next parameter.
5. Press *'escape'* button to exit from parameter settings menu.

☞ EXAMPLE: Setting the stop number

- Press *'enter'* button to enter the parameter setting menu,
- Press *'up'* button until find *'stop'* parameter
- Press *'enter'* button again, stop number will blink,
- Choose the stop number using the *'up'* and *'down'* buttons
- Press *'enter'* button to memorize the value and pass the next parameter setting.

PARAMETER LIST

PARAMETER	SETTING LIMITS	FACTORY VALUE	EXAMPLE
MANUAL CALL	0 - 9	0	MANUAL FLOOR CALLING
Program Settings 1-Get Inspection	-	-	Be operated at inspection mode on card UP / DOWN
Program Settings 2-Stops Number	1 -- 10	10	Adjustable stop number
3-Collective Type	1- Home lift 2- Mix. collective 3- Down collective 4- Full collective .	2- mix. collective	-
4-Door Type	1-Manual 2-Semi automatic 3-Full automatic	1- semi automatic	-
5-SHAFT COM.TYP	1- paral . data 2- Car serial . data 3- Full serial	1- paral . data	-
6-Shaft Reading T	1-2mono stable 2-M1 bi stable 3-M1 mono stable	2- M1 bi stable	-
Program Settings 7- Park Floor	0 – 09	10	Choose '10' to cancel fire stop
Program Settings 8- Str-Dlt Tm	000-100	0	-
9-Set KSR Mode	1-Go on KSR 2-Stop on KSR	1-Go on KSR	-
10-Disp.Out Type	1- Disp. Sev. Seg. 2- Disp. Binery 3- Disp Flr.Out	1- Disp. sev. seg.	-
11-Working Type	1. Two Speed 2. Fuji Inverter 3. Yaskawa Inv. 4. Lg Inv.	1. Two Speed	-
12-Position Reset	1- Reset. Active 2 -Reset. Passive	2 -Reset. Passive	Reset operation after power cut
13-Lift Type	1-Lift Simplex 2 –Doublex A 3– Doublex B	1-Lift Simplex	Lift Running Mode
14-Safety Volt	040 – 220 V	220 V	-

PARAMETER	SETTING LIMITS	FACTORY VALUE	EXAMPLE
15.Shft Wrk. Type	1-Lift Rope 2-Hydrolic	1-Lift Rope	Type Of The Lift
16-Ucm Control	1. Passive 2. Active	1. Passive	Control For Overspeed Governor Switch (ONLY FOR A3)
Time Settings 17-Flr Wait	002-050	003	Before Go To New Call
Time Settings 18-Fst Speed	001-059	010	-
Time Settings 19-Slw Speed	001-059	010	-
Time Settings 20-Busy Time	001-100	005	Time to wait before the next record
Time Settings 21-Cls Door	001-059	007	Limit of door closing time
Time Settings 22-Opn Door	001-059	007	Limit of door opening time
Time Settings 23-Ups Resc.	1-000 2-001	000	Ups mode (001 is active)
Time Setting 24-Lock Waiting	1 – 30 s	8 s	After pump pull, lock will wait up to the chosen value
Time Setting 25-Brk Wait	0 – 1 s	1 s	Time of brake run after the floor arriving
Time Setting 26-Ups Strt	0 – 50 s	0 s	Time of ups run after the Power outages
Time Setting 27-Park Time	000-020	0	Time In Minute Before Go To The Park Floor
Time Setting 28-Level Time	000-059	0	Limit For Releviling (sec)
Program Settings 29-Display Settings	00,01,02,03,04,05,06 07,08,09,10,11,12,13 14,15,A,b,C,d,L,-1,-2,-3	00,01,02, 03,04,05,06 07	Floor information shown on the display
Program Settings 30-Door Settings	D1 - FLR . 00 – 09 OPEN D2 - FLR . 00 – 09 OPEN ----- D1 - FLR . 00 – 09 -o.wait D2 - FLR . 00 – 09 -c.wait	D1 OPEN D2 N.OPEN ----- D1 C.WAIT D2 C.WAIT	Chosen open/close state for automatic doors The D1 is the auto relay The D2 is the aux relay In first menu show open or not open door in floor In second menu select door stay open or close in floor

PARAMETER	SETTING LIMITS	FACTORY VALUE	EXAMPLE
Program Settings 31-Default Settings	Default Active	ESC	Press enter to reset to factory setting or escape to exit to cancell
Program Settings 32-Auxiliary Input Sel.	(EMP, , 142 , 817 , 818 , M0 , M1 , M2 , M3 , UPS , KG , 869 , 500 , 501 , 804 , K20 DTS, , T2)	AUX.1 EMP AUX.2 EMP	Use The GP1 Input In Card If You Select Input In The AUX.1 INPUT Use The GP2 Input If You Select Input In The AUX.2 INPUT (Only Use For Spare)
Program Settings 33-Auxiliary Output Sel.	(EMP , RU1, RU2, RH, RF, CAM, CL, AUT , 031, 032, 12, 02)	EMP	Use The AUX Relay In Card If You Select Output In The AUX.1 RELAY (Only Use For Spare)
Program Settings 34-Phases Prot.	1- Protect Pass. 2- Protect Active.	1	Phase Control Mode.
Program Settings 35-Phases Seq.	1- Protect Pass. 2- Protect Active. 3- Protect FIX.	3- Protect FIX.	Phase Sequence Mode. 1-With out fix If Phase Wrong. 2- VVVF device Fix.(vvvf) 3- With fix Phase (two speed).
Program Settings 36-Level Set.	1-Level. Passive 2-Level. Active	1	Level Mode.
Program Settings 37-Pin Code Set	-	-	If You Need Make A Lock For Card In
Lift Start 38-Start Qty	00000-99999	0	Choose '0' to cancel it
39-Calls Button	1. Button Locked 2. Button Toggle	1.ButtonLocked	Set it at button toggle to cancel unwanted car orders These feature can running only with parallel shaft systems
40-Missing Floor	MIS FLR BELOW 00 MIS FLR ABOVE 00	00 00	To Cancel Floor

AUXILIARY INPUT AND OUTPUT SETTINGS

There are;

- 2 auxiliary input
- 1 auxiliary output (relay), existing on the board for general purpose.

Auxiliary Input (GP1 or GP2):

If there occurs a problem in one of the inputs on the card (T2, 142, 817, 818, M1, KG, 869, 500, 501, 803, 804, 805, K20, DTS) as a result of any reason such as short circuiting or wrong wiring... change the parameter input with the auxiliary input (GP1/GP2) without moving the card out of the panel. After this change the card will continue its normal operation.

☞ **EXAMPLE:** If the '142' input failed:

- Put off the wire of the '142' connector on the card and put the same wire on 'GP1/GP2' connector.
- Enter the parameter settings menu and come to the 'aux. input sel' parameter,
- Press 'enter' button, set the 'aux. input' value as '142' by using the 'up' button. Press 'enter' button to store last change in the memory. After this setting the 'GP1/GP2' input will operate as '142' input.
- **This process can be applied to the all inputs on the card**

Auxiliary Output (AU):

If there occurs a problem with one of the relays on the card (RU1, RU2, RH, RF, CAM, CL, AUT , 031, 032, 12, 02) this auxiliary input can be used instead of the broken relay.

☞ **EXAMPLE:** If 'CAM' relay is failed;

- Change the wire of 'P1' connector with the one of the 'AU' connector, and the wire of 'P2' connector to the other 'AU' connector,
- In the parameter settings mode, find the 'aux. output sel.' parameter and press 'enter' button,
- Choose 'auxiliary output' as 'CAM' by using 'up' button and memorize it by pressing 'enter' button,
- **This process can be applied to the all relay outputs on the card.**

Usage Tips

In order to be exact convenience of the lift system to the EN 81-1/2 standards as electrically, the control card, control panel, security circuit and electrical connections must be convenient to concerned standards. The producers whom willing to build panel with SKY 301-V6 must have enough level of information and experience about EN 81-1/2 standard and other standards, regulations, and instructions. SKY ELEVATOR assumes no responsibility for panels not build towards the given directions. SKY ELEVATOR guarantees that SKY 301-V6 is convenience to the EN 81-1/2 but inside and outside connections of the control panel and other electrical connections are under responsibility of mounter.

- ☞ There must be 10mm distance between the SKY 301-V6 control card and the panel.
- ☞ The SKY 301-V6 control card must be fixed from 4 holes at the edges.
- ☞ After the puncturing to place SKY 301-V6 card and other components in the panel, the panel must be cleaned very carefully from iron pieces and conductor wires otherwise these pieces can be cause damage while transferring the panel from somewhere to another.
- ☞ The contactors that are used for the AC motor lifts must be chosen according to the EN60947 AC3 class and must be enduring for the motor power. The connection must be done according to the directions shown in the SKY 301-V6 schema.
- ☞ The cooperative motor placed on the main contactors must be chosen according to the EN60947 and must be controlled that contactors are active/inactive in the same time with power contacts.
- ☞ The bridge diode connections of the brake and pump must be done according to the schema and must be used isolated lugs.
- ☞ Panel manufacturer must control all the connections and do the required tests after finishing the panel.

- ☞ The connections between the control panel and motor; car and lift shaft must be done carefully according to the SKY 301-V6 schema.
- ☞ The 3-phase supply voltage must be connected to the R, S, T connectors on the panel with suitable fuse (chosen due to motor power) and network neutral must be connected to the MP connector.
- ☞ Grounding cables and neutral must be separately connected and the panel body must be perfectly grounded.
- ☞ All stopper linkages specified in EN 81-1/2 standards must be placed in lift and the connections of these linkages must be done to the control panel according to the SKY 301-V6 schema. All the used contactors must be convenient to the EN 60947 standards.

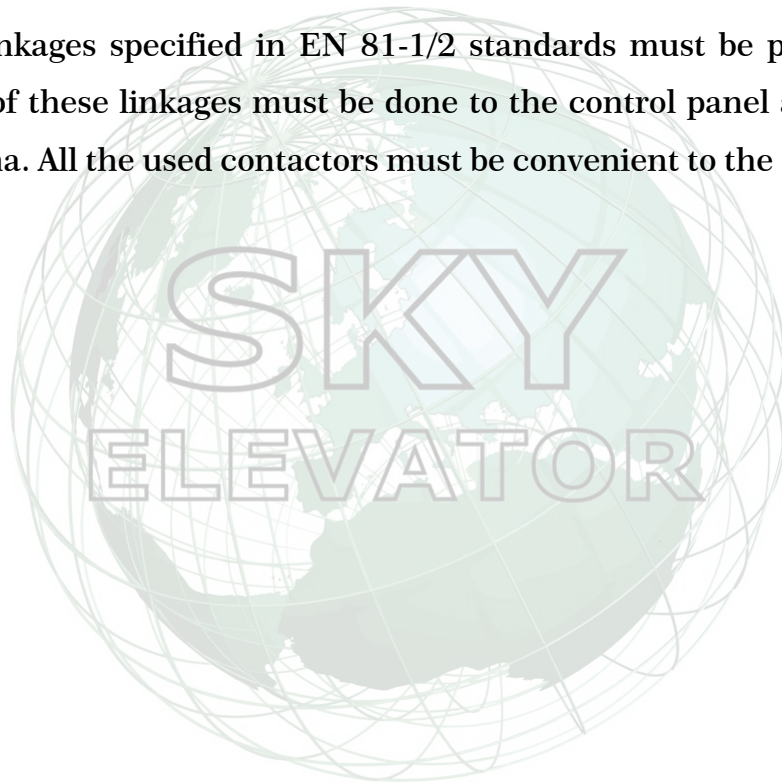

USAGE TIPS IN CONTROL PANEL

- ☞ Be sure that the connections between the control panel and lift system are done according to the SKY 301-V6 schema.
- ☞ Control if there is any short circuit in the connections with a suitable measuring device.
- ☞ Take the '*control panel revision switch*' to 'ON' position.
- ☞ Take the '*motor protection circuit stopper*' to 'ON' position and turn on the panel electric.
- ☞ Control that the led of '02' on the board and 'out of service' lamp on the floor buttons are light up.
- ☞ Control that the voltage between the 100 – 1000 connectors is 10-35V DC.
- ☞ Be sure that all security contacts are connected according to the schema and operates correctly. Control the security inputs activity from 120, 130, 140 leds.
- ☞ The revision switch on the control panel is in ON position so the car will operate only at low speed. Control that the low speed coil is correctly coiled by routing the car with the *up* and *down* buttons placed on the control panel. If the car goes to wrong direction change place of any two ends (U2, V2, W2) of low speed coil on the control panel.
- ☞ Measure the voltage between 2001 – 810 and 2000 – 840 connectors while car is in motion. The value must be in 180 – 240V DC interval.
- ☞ Place the car on one of the middle floors and take the '*car top revisions switch*' to 'OFF' position. The 'Out of Service' indicators will turn off on the floor buttons
- ☞ Be sure that the lift going the true direction by giving log (call)s if it operated wrong change place of any two connections (U2, V2, W2).

RISK ANALIZE

Please check to the safety circuit dip switch if currently before running

The contactor connector (11A) on the SKY 301-V6 card must be connected to the security system turning.

Panel direction and motion connectors do *not* be closed by hand. In such case security circuits can *not* block motion of the lift.

The 24V DC fuse on the card must not be shunted. If the fuse blows constantly look for a short circuit at the shaft system and inside the panel.

Car lamp supply voltage (1F) must be connected to the one of the main phases before thermic relay.

When motor calefacted, the motor thermistor ends must be connected to the 'T2' connector to avoid the car stay between the floors.

Door frames must be connected to the grounding bar. If grounding is not proper, security circuits have a risk of shunted through door chassis.

After long time operations, dust, dirt, oil can be affect the performance of the security system. Please do not ignore plug and lock functions in periodic controls.

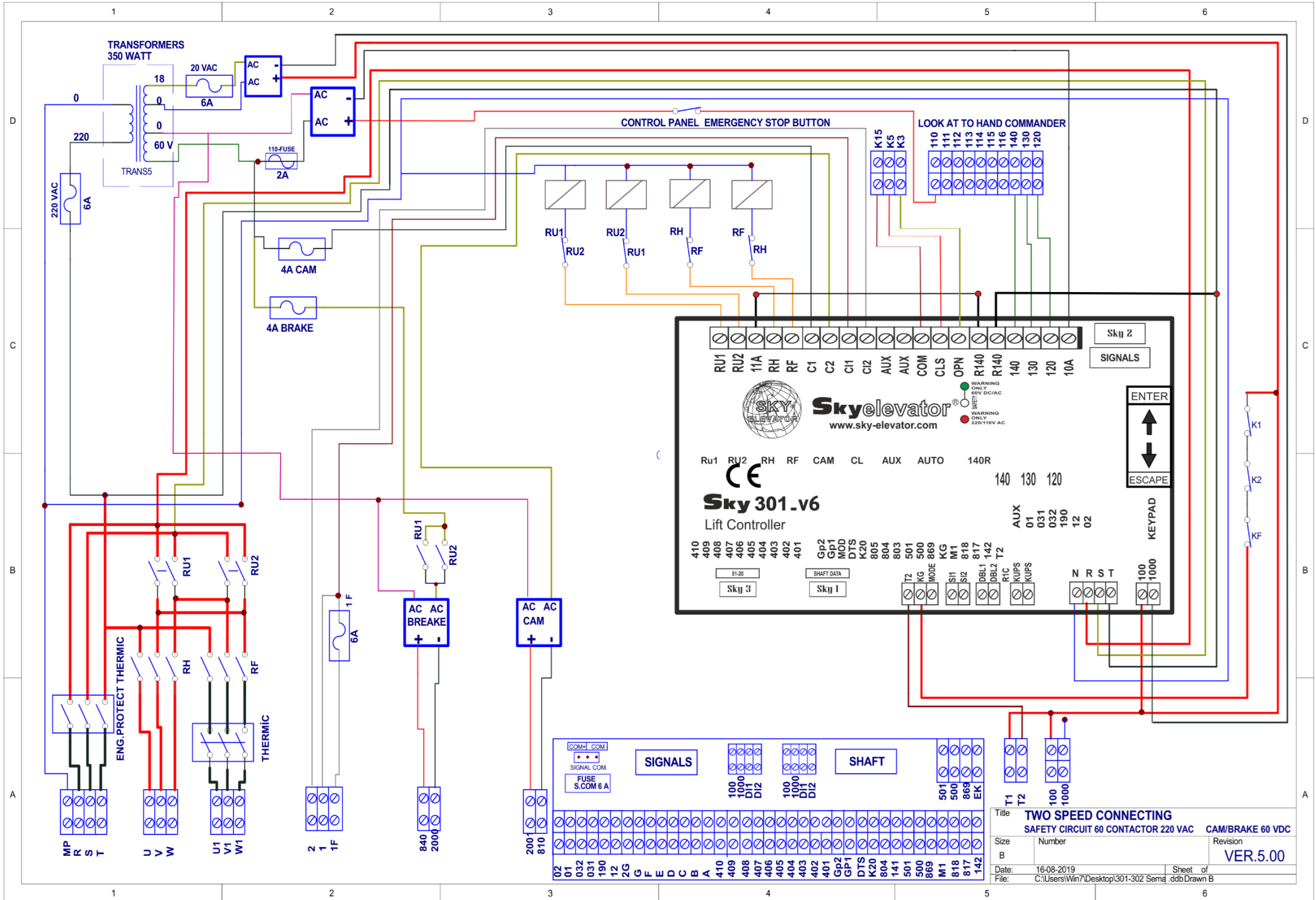

Title		TWO SPEED CONNECTING	
Size		SAFETY CIRCUIT 60 CONTACTOR 220 VAC CAM/BRAKE 60 VDC	
Number		Revision	
B		VER.5.00	
Date:	16-08-2019	Sheet of	
File:	C:\Users\Win7\Desktop\301-302 Sem2.ddb Drawn B		

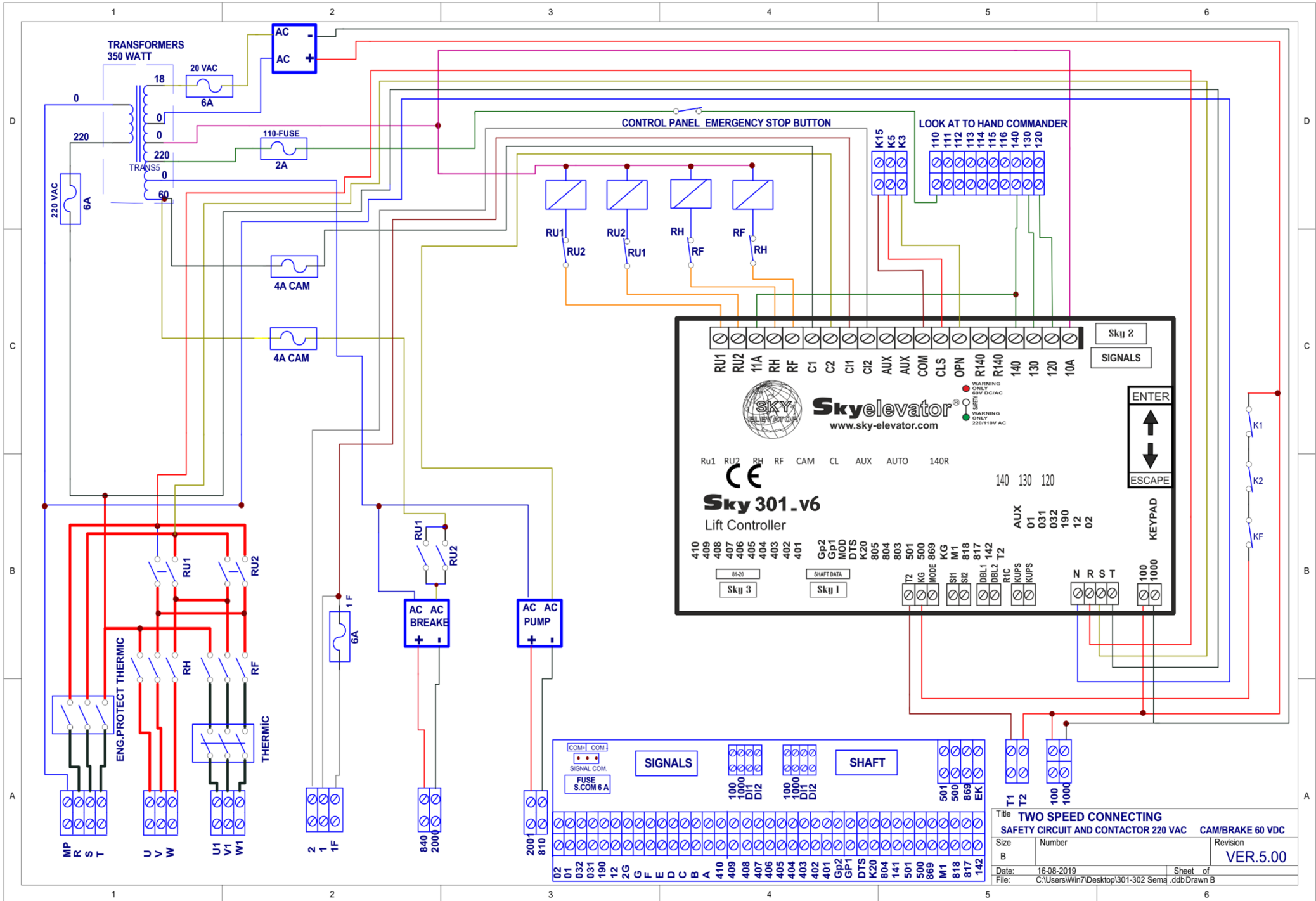

Title		TWO SPEED CONNECTING	
Size		SAFETY CIRCUIT AND CONTACTOR 220 VAC CAM/BRAKE 60 VDC	
Number	Revision	VER.5.00	
Date: 16-08-2019	Sheet of		
File: C:\Users\Win7\Desktop\301-302 Sema.ddb Drawn B			

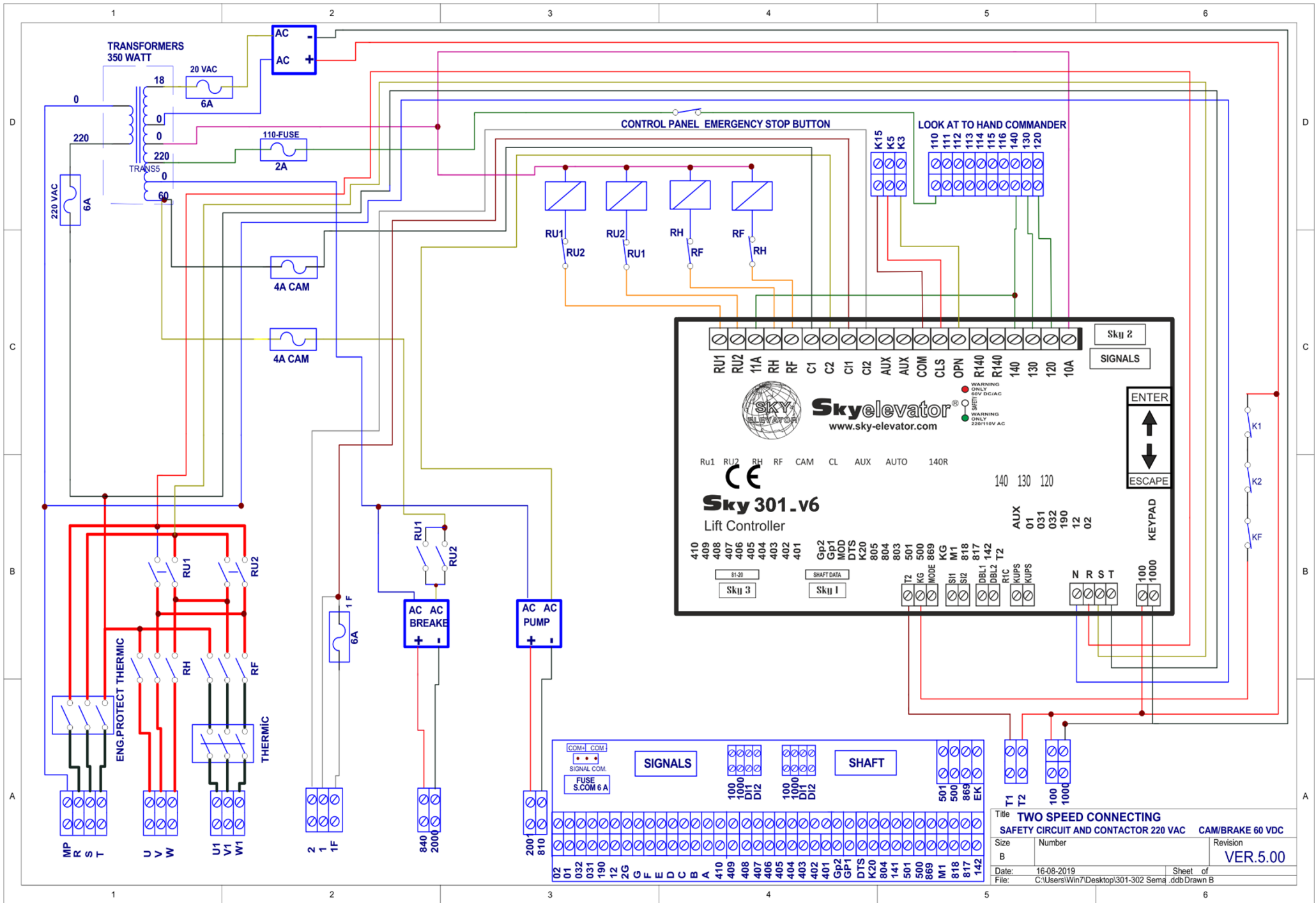

Title **TWO SPEED CONNECTING**
 SAFETY CIRCUIT AND CONTACTOR 220 VAC CAM/BRAKE 60 VDC
 Size Number Revision
 B VER.5.00
 Date: 16-08-2019 Sheet of
 File: C:\Users\Win7\Desktop\301-302 Sema.ddb Drawn B



BISTABLE MAGNET CLOSE



BISTABLE MAGNET OPEN

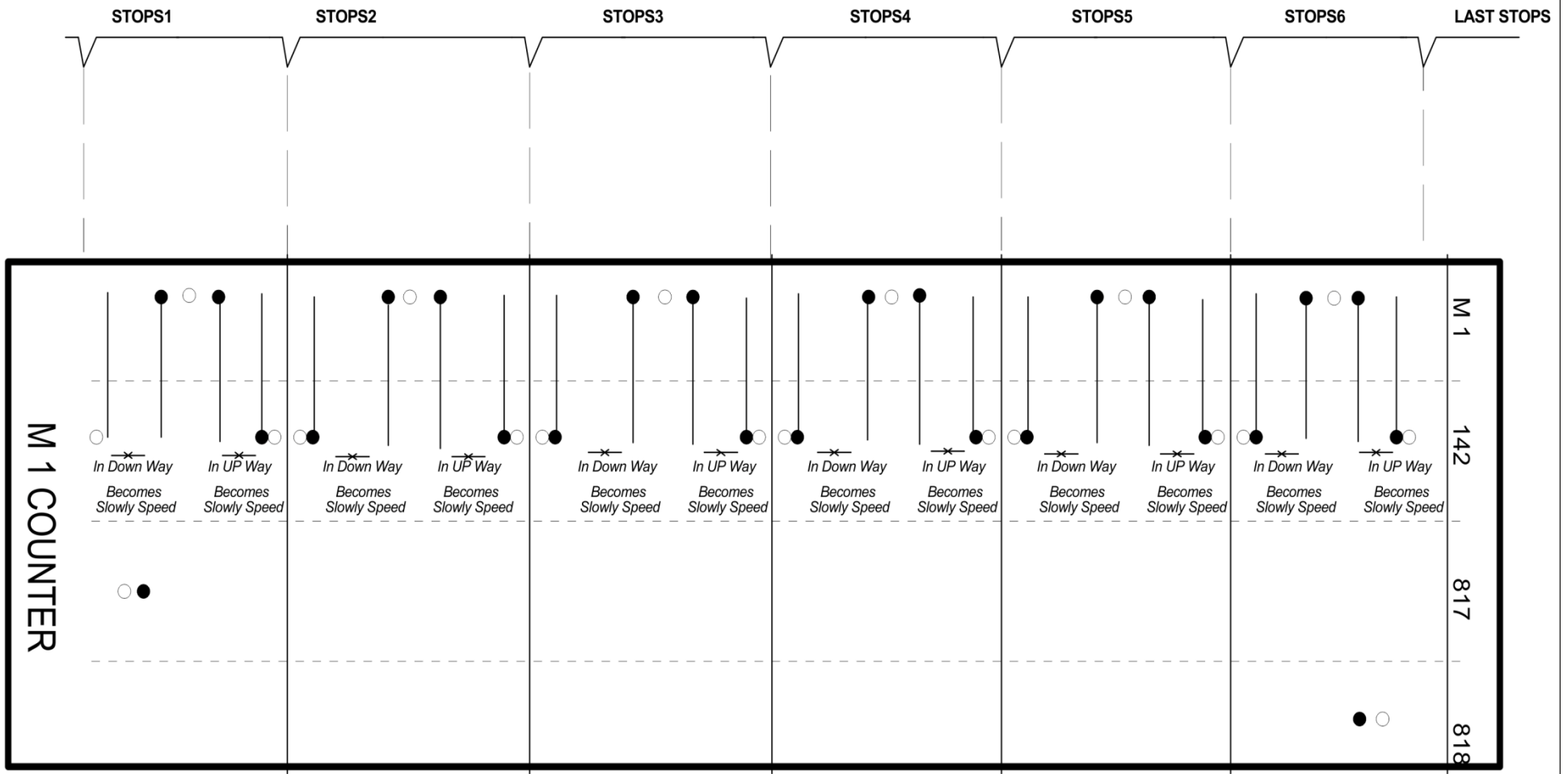

Title		
MAGNETS SHAPE M1		
Size	Number	Revision
B		
Date:	18-Jun-2015	Sheet of

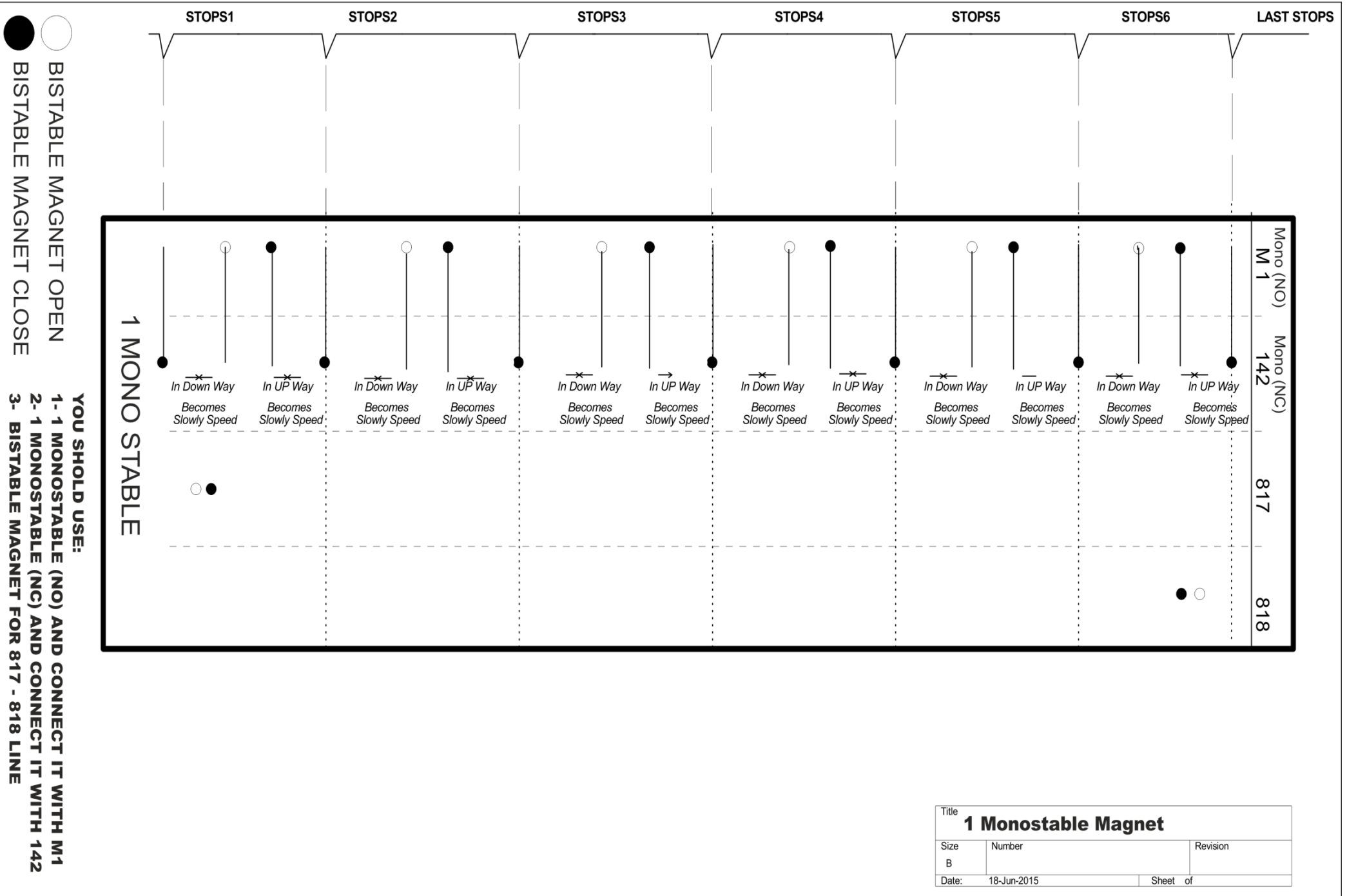

Title		
1 Monostable Magnet		
Size	Number	Revision
B		
Date:	18-Jun-2015	Sheet of

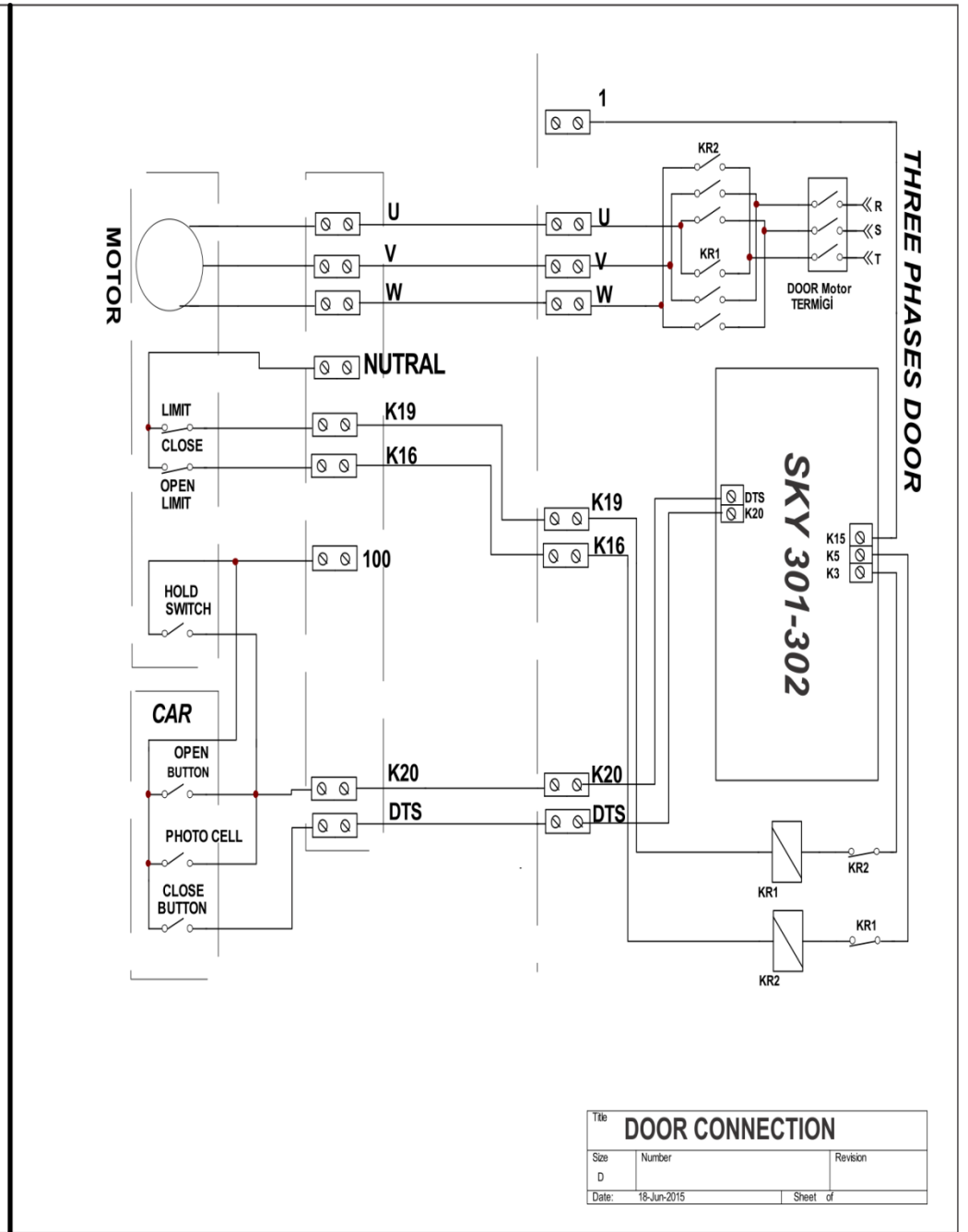
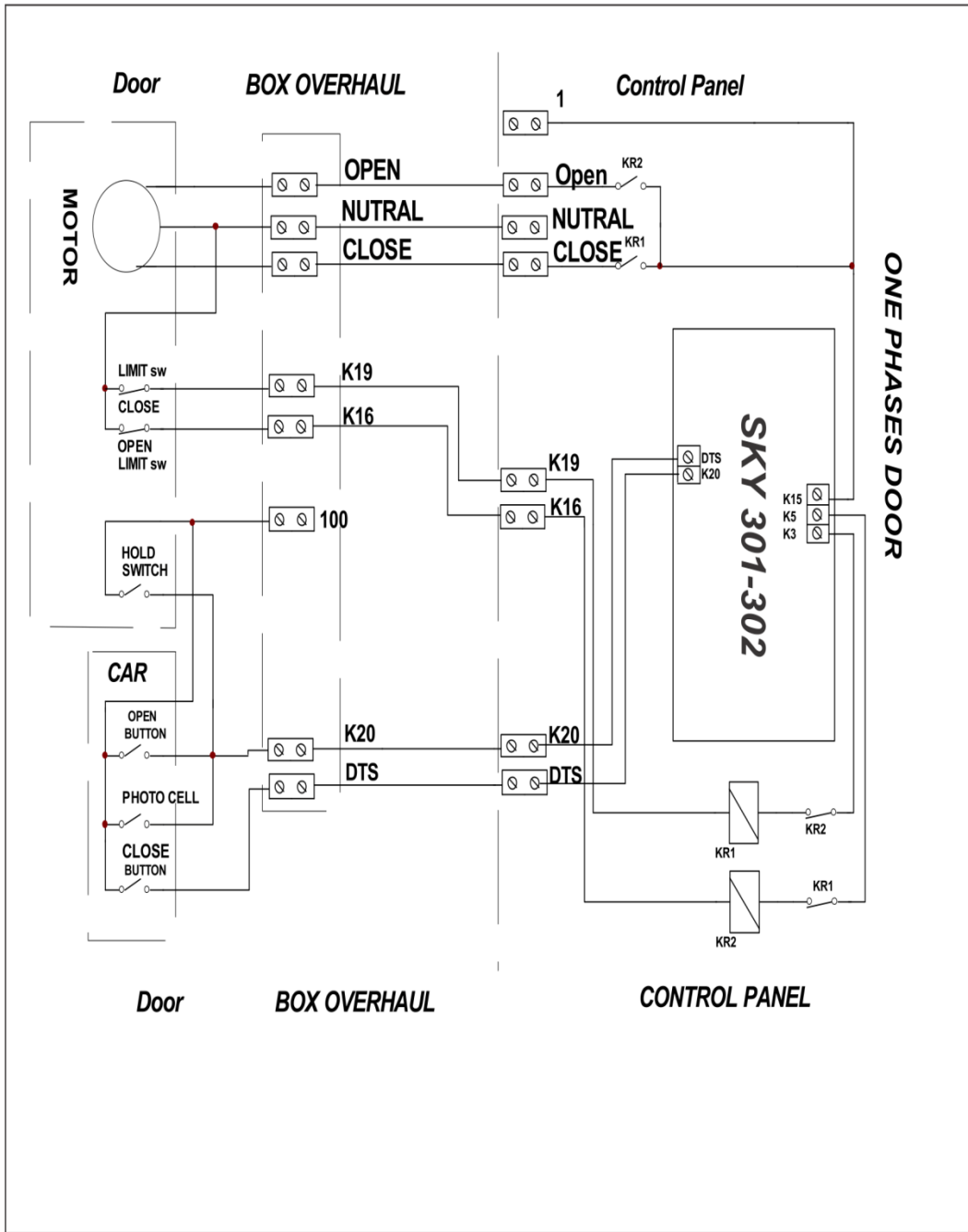

Title		
DOOR CONNECTION		
Size	Number	Revision
D		
Date:	18-Jun-2015	Sheet of

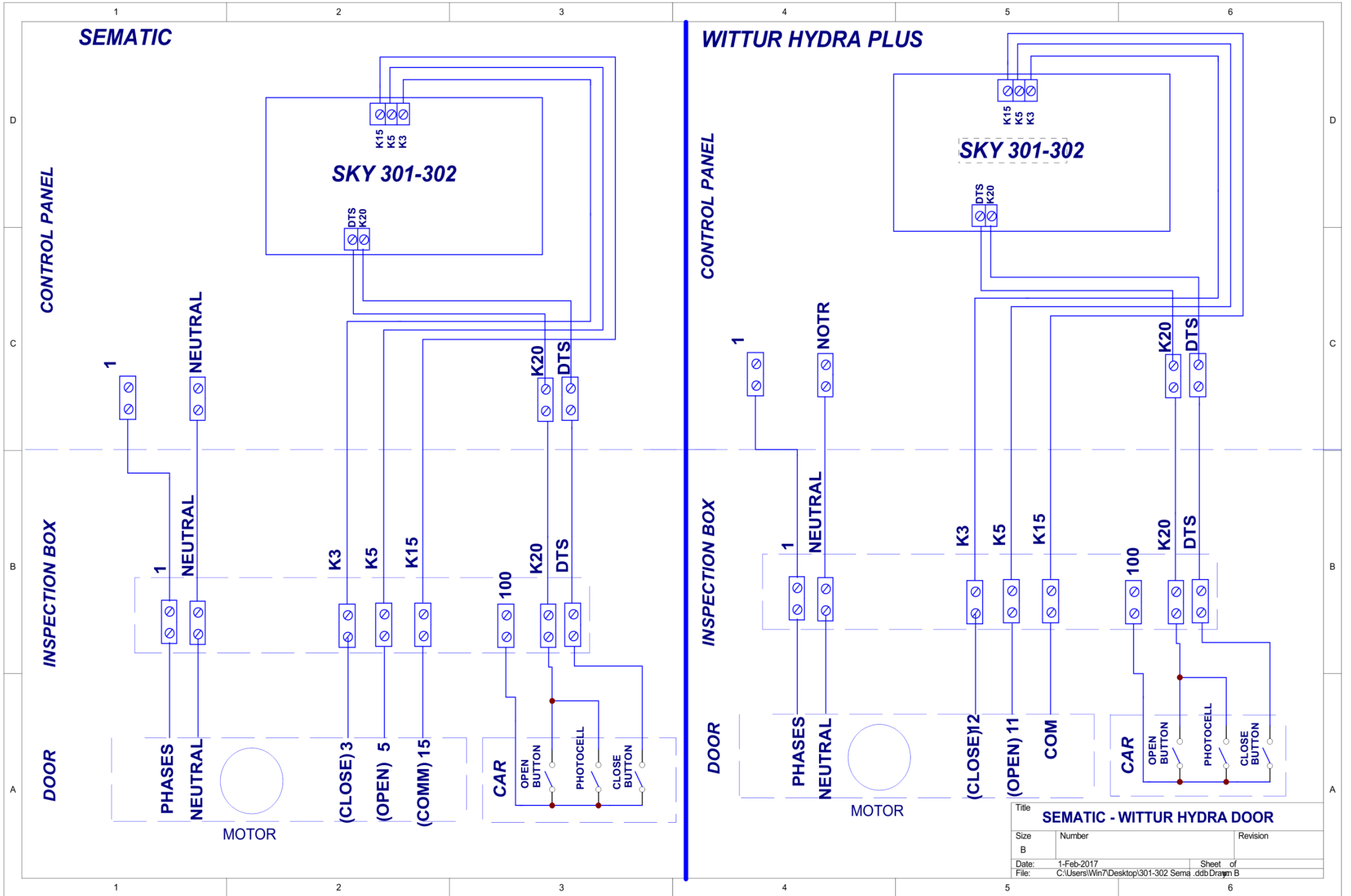

Title		
SEMATIC - WITTUR HYDRA DOOR		
Size	Number	Revision
B		
Date:	1-Feb-2017	Sheet of
File:	C:\Users\Win7\Desktop\301-302 Sema.ddb	Drawn B

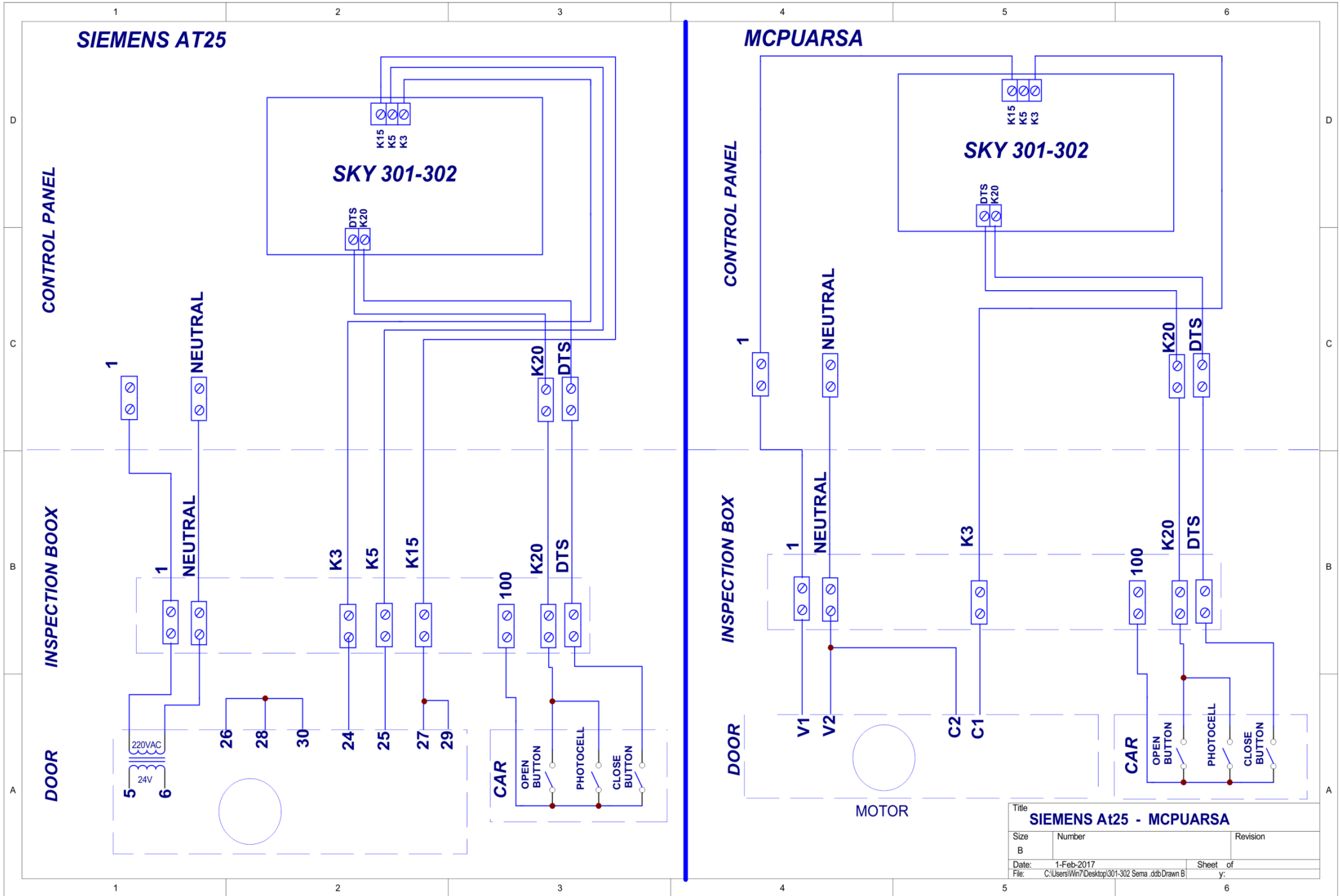

Title			
SIEMENS At25 - MCPUARSA			
Size	Number	Revision	
B			
Date:	1-Feb-2017	Sheet	of
File:	C:\Users\Win7\Desktop\301-302 Sema.ddb\Drawn B	y:	

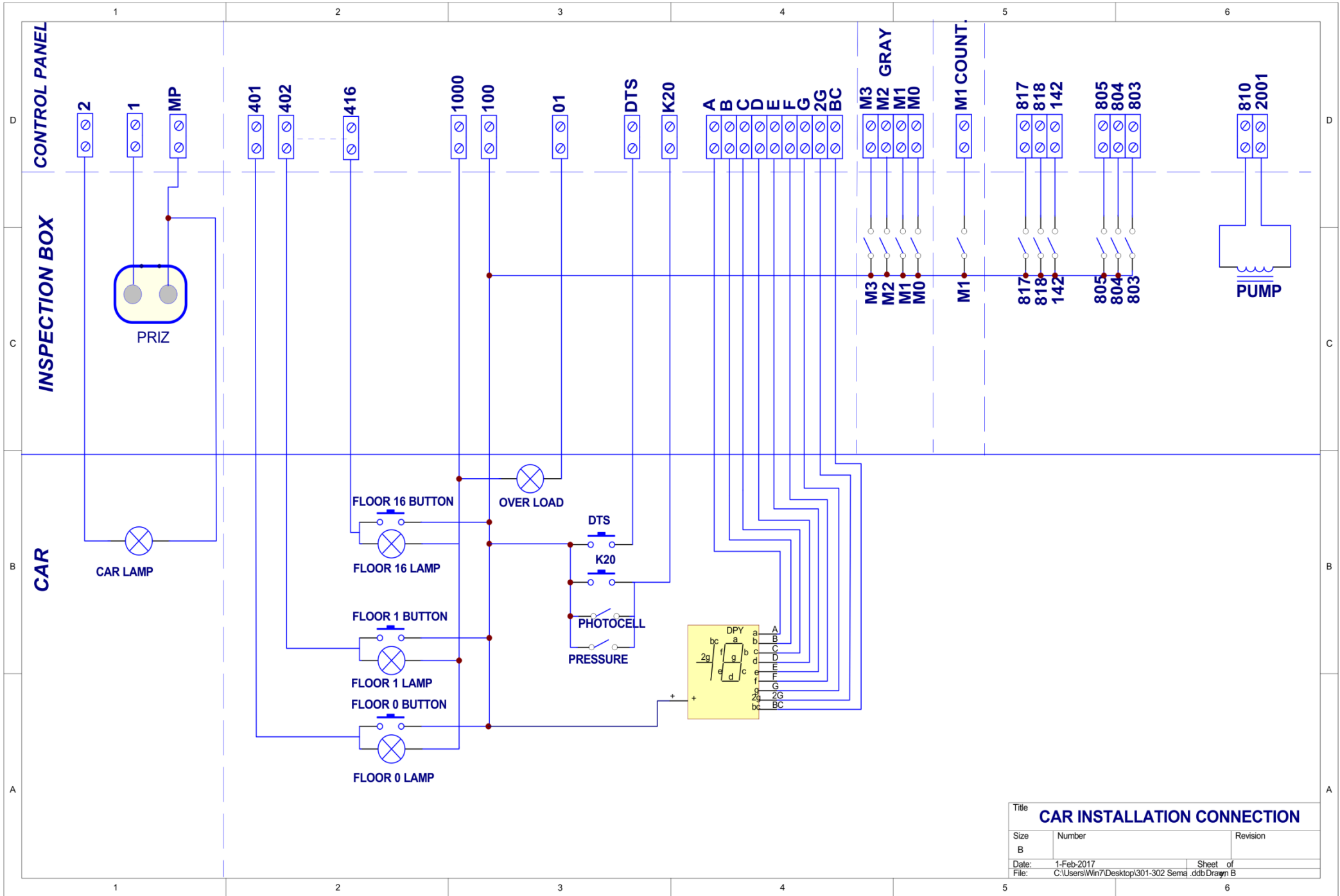

Title		
CAR INSTALLATION CONNECTION		
Size	Number	Revision
B		
Date:	1-Feb-2017	Sheet of
File:	C:\Users\Win7\Desktop\301-302 Sema .ddb Drawn B	

IF 100 (+24V) INPUT TO SIGNAL COMMON (S.COM) SIGNAL OUTPUT (12,02,031,032) WOULD BE(+24V) AND IF 1000 (-24V) INPUT TO SIGNAL COMMON (S.COM), SIGNAL OUTPUT(12,02,031,032) WOULD BE(-24V)

BASIC COMMAND

MIXED COLLECTIVE

DOWN / UP COLLECTIVE

DOUBLE BUTTON COLLECTIVE

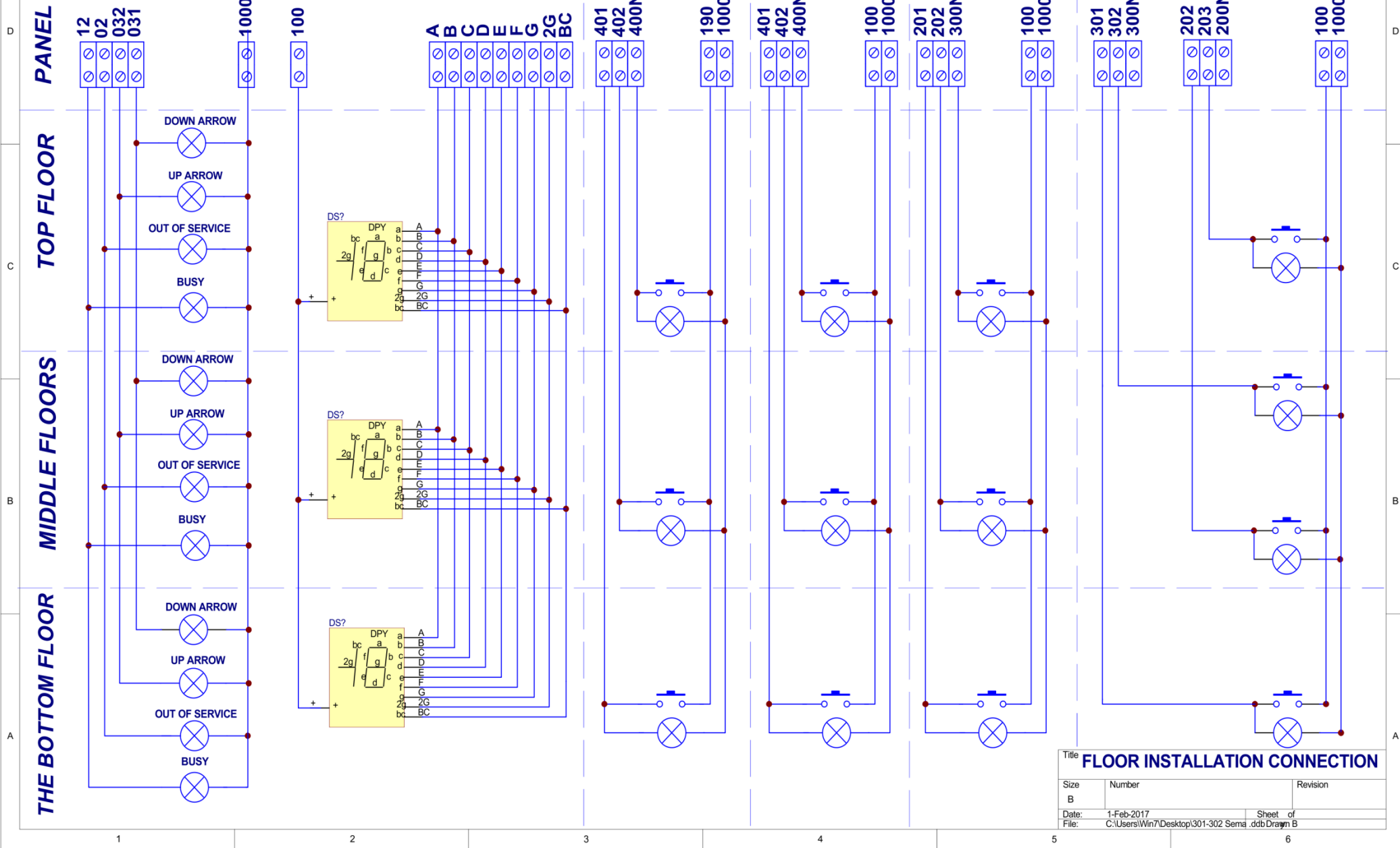

Title **FLOOR INSTALLATION CONNECTION**

Size	Number	Revision
B		
Date:	1-Feb-2017	Sheet of
File:	C:\Users\Win7\Desktop\301-302 Sema .ddb Drawn B	

EMERGENCY ELECTRICAL OPERATOR SWITCH

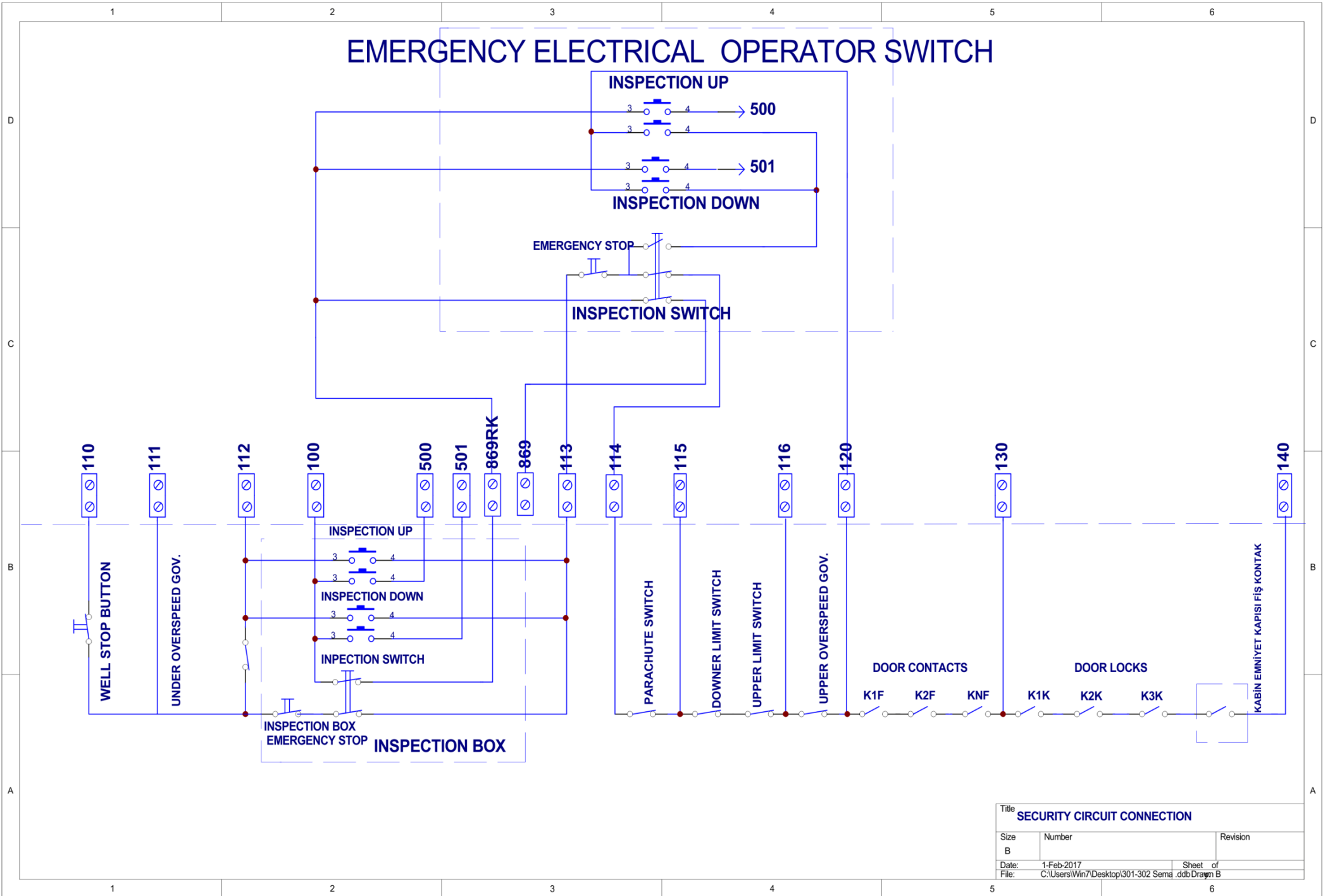

Title SECURITY CIRCUIT CONNECTION		
Size B	Number	Revision
Date: 1-Feb-2017	Sheet of	
File: C:\Users\Win7\Desktop\301-302 Sema.ddb Drawn B		

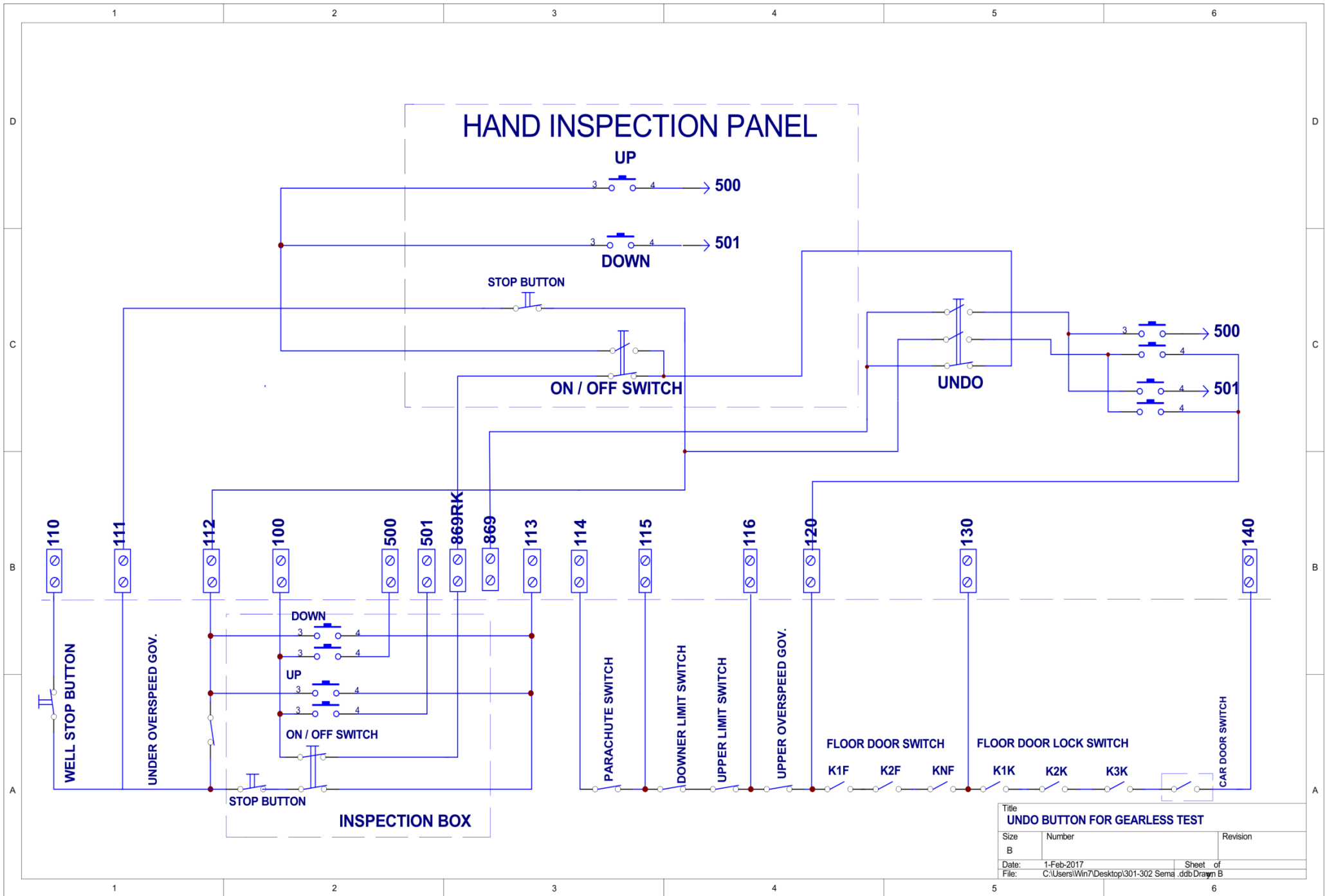

Title		
UNDO BUTTON FOR GEARLESS TEST		
Size	Number	Revision
B		
Date:	1-Feb-2017	Sheet of
File:	C:\Users\Win7\Desktop\301-302 Sema .ddb Drawn B	



Sky Elevator®
Elevator Systems & Spare Parts



DIN EN ISO
9001:2015
CE

GLOBAL BRAND



YOU'RE SAFE WITH US

ALWAYS CHOOSE THE RISING QUALITY

www.sky-elevator.EU

www.sky-elevator.com